

### Specifications

- Current rating:3A AC,DC
- Voltage rating:250V AC,DC
- Temperature range:-25°C~+85°C
- Contact resistance:30mΩMax.
- Insulation resistance:1000MΩMin.
- Withstanding voltage:1000V AC/minute
- \*Compliant with RoHS and REACH\*
- \*Meet the HF/Halogen Free,need to customize\*
- \*Contact HDGC for details\*

### Assembly layout

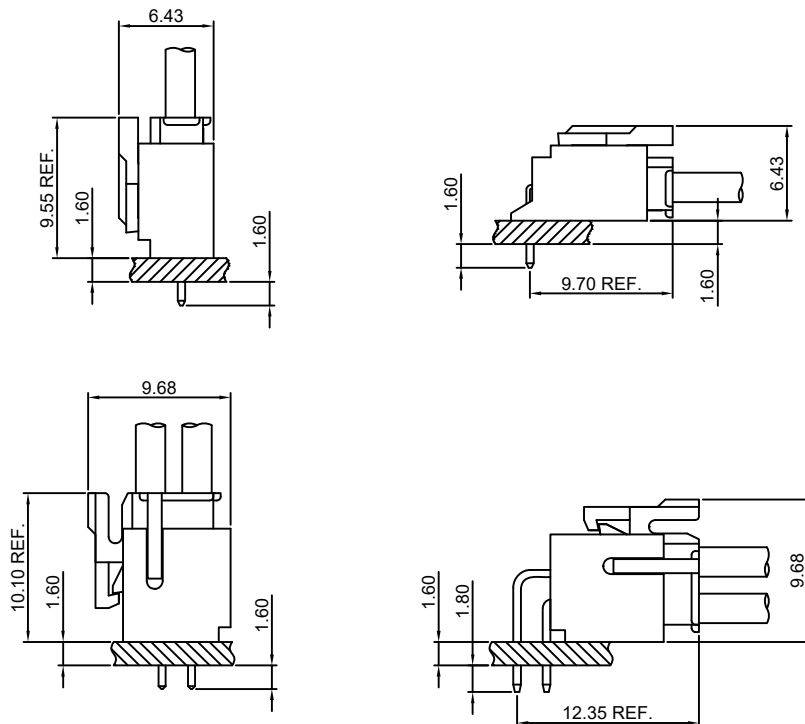



## HDGC2008 Series 2.00mm (.079") Pitch Wire to Board and Wire to Wire Connector

### HDGC2008-T

2.00mm pitch Crimp Terminal

#### Reference Informations:

\*Used in HDGC2008H-XP, 2009H-2xXP series Housing

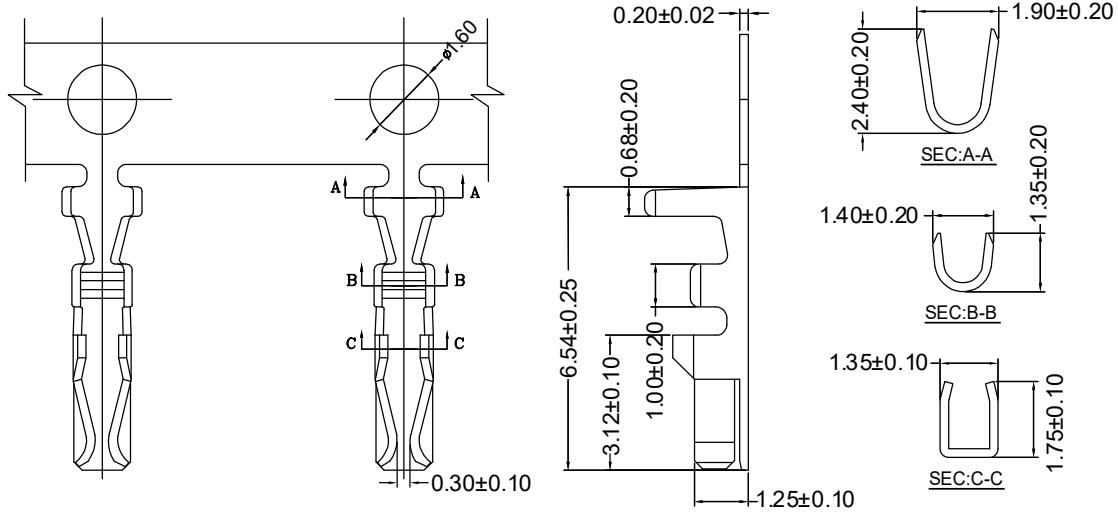

Ordering information & Specifications:

Unit:mm

| Part NO.    | Wire Range | Insulation O.D. | Material        | Finish           | Qty/reel   |
|-------------|------------|-----------------|-----------------|------------------|------------|
| HDGC2008-TP | AWG#22-#30 | 1.45mm(max)     | Phosphor Bronze | Tin over Nickel  | 12,000 PCS |
| HDGC2008-GP | AWG#22-#30 | 1.45mm(max)     | Phosphor Bronze | Gold over Nickel | 12,000 PCS |

Optional Gold plating available but MOQ requested

### HDGC2008-T-A

2.00mm pitch Crimp Terminal

#### Reference Informations:

\*Used in HDGC2008HB-XP, 2008H-2xXP series Housing

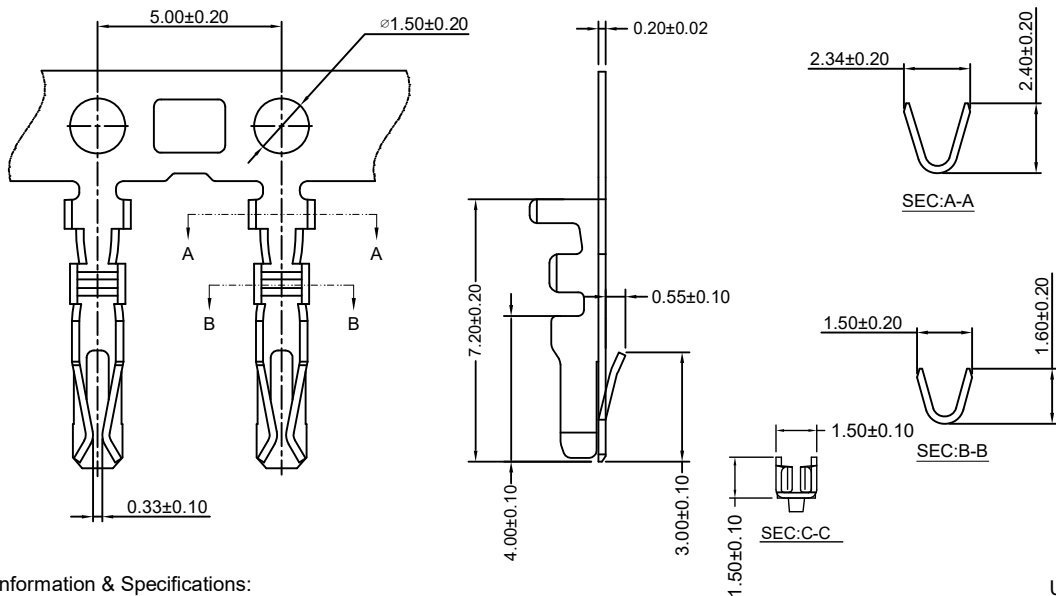

Ordering information & Specifications:

Unit:mm

| Part NO.      | Wire Range | Insulation O.D. | Material        | Finish           | Qty/reel   |
|---------------|------------|-----------------|-----------------|------------------|------------|
| HDGC2008-TP-A | AWG#22-#30 | 1.45mm(max)     | Phosphor Bronze | Tin over Nickel  | 10,000 PCS |
| HDGC2008-GP-A | AWG#22-#30 | 1.45mm(max)     | Phosphor Bronze | Gold over Nickel | 10,000 PCS |

Optional Gold plating available but MOQ requested



## HDGC2008 Series 2.00mm (.079") Pitch Wire to Board and Wire to Wire Connector

### HDGC2008M-T

2.00mm pitch Crimp Terminal

#### Reference Informations:

\*Used in HDGC2008HM, HMB-XP series Single Row Housing

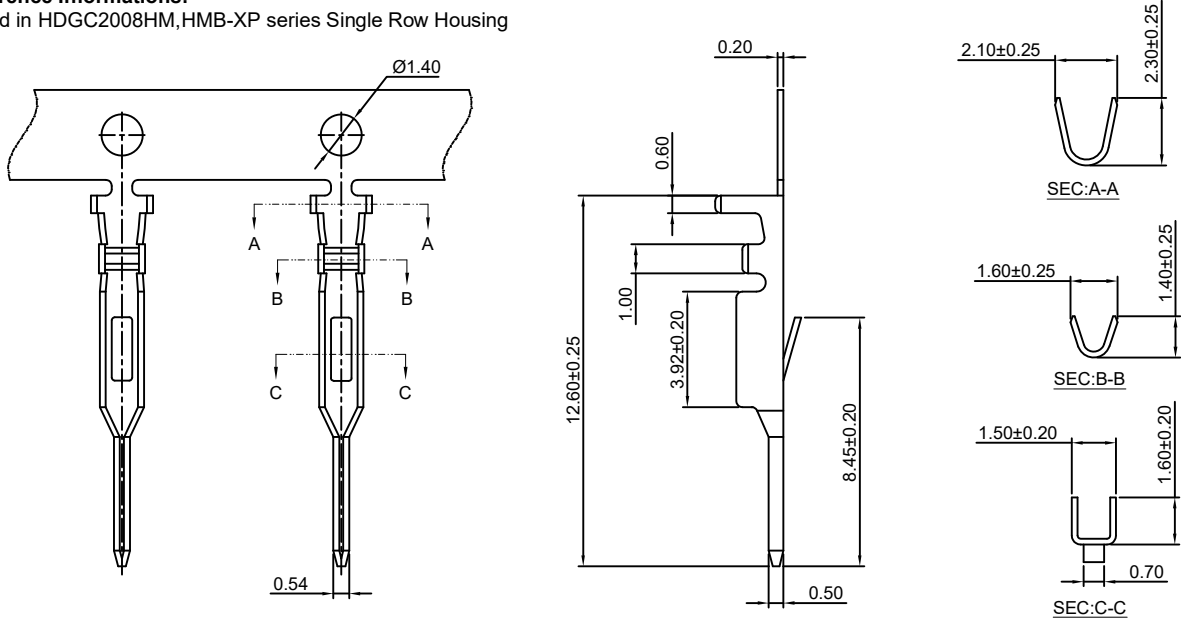

Ordering information & Specifications:

Unit:mm

| Part NO.     | Wire Range | Insulation O.D. | Material        | Finish           | Qty/reel   |
|--------------|------------|-----------------|-----------------|------------------|------------|
| HDGC2008M-TP | AWG#22-#28 | 1.50mm(max)     | Phosphor Bronze | Tin over Nickel  | 15,000 PCS |
| HDGC2008M-GP | AWG#22-#28 | 1.50mm(max)     | Phosphor Bronze | Gold over Nickel | 15,000 PCS |

Optional Gold plating available but MOQ requested

### HDGC2008H-XP

2.00mm pitch Housing

#### Reference Informations:

\*Material:Nylon 66,UL94V-0

\*Suitable HDGC2008-T series Terminal

\*Mates with HDGC2008HM, HMB-XP series Single Row Housing or HDGC2008WV, WR, WV-S, WR-S-XP series Single Row Wafer

\*Color:White

#### Ordering Information:

HDGC2008H-XP - \*\*\*  
1 2

1.Part No.

2.Material:

(Blank):Nylon 66,UL94V-0

GWT:Nylon 66,UL94V-0,GWT 750°C

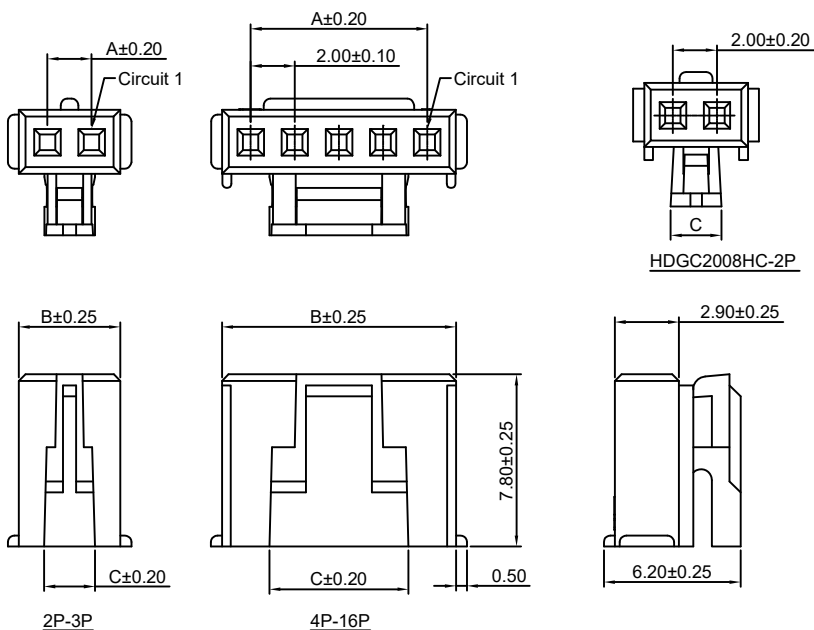
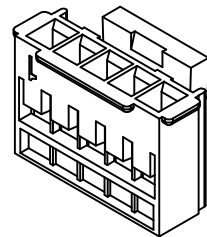

#### Ordering Information & Dimensions:

| PART NO. | Dimensions |       |       |
|----------|------------|-------|-------|
|          | A          | B     | C     |
| 2P       | 2.00       | 4.60  | 2.30  |
| 3P       | 4.00       | 6.60  | 2.30  |
| 4P       | 6.00       | 8.60  | 4.30  |
| 5P       | 8.00       | 10.60 | 6.40  |
| 6P       | 10.00      | 12.60 | 6.40  |
| 7P       | 12.00      | 14.60 | 6.40  |
| 8P       | 14.00      | 16.60 | 6.40  |
| 9P       | 16.00      | 18.60 | 6.40  |
| 10P      | 18.00      | 20.60 | 14.40 |
| 11P      | 20.00      | 22.60 | 14.40 |
| 12P      | 22.00      | 24.60 | 14.40 |
| 13P      | 24.00      | 26.60 | 14.40 |
| 14P      | 26.00      | 28.60 | 14.40 |
| 15P      | 28.00      | 30.60 | 14.40 |
| 16P      | 30.00      | 32.60 | 14.40 |

Unit: mm



## HDGC2008 Series 2.00mm (.079") Pitch Wire to Board and Wire to Wire Connector

### HDGC2008HA-XP

2.00mm pitch Housing

#### Reference Informations:

- \*Material:Nylon 66,UL94V-0
- \*Suitable HDGC2010-T series Terminal
- \*Mates with HDGC2008WVA,WRA-XP series Wafer
- \*Color:Ivory

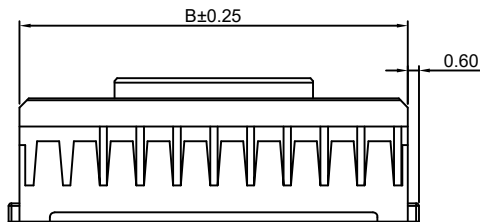
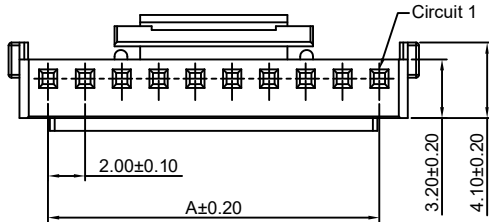

#### Ordering Information:

HDGC2008HA-XP - \*\*\* - \*\*  
1 2 3

- 1.Part No.
- 2.Material:  
(Blank):Nylon 66,UL94V-0  
GWT:Nylon 66,UL94V-0,GWT 750 °C
- 3.Color:  
(Blank):White  
BK:Black  
RD:Red  
YL:Yellow  
BL:Blue  
GN:Green  
GY:Gray

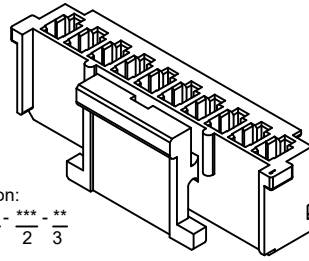

#### Ordering Information & Dimensions:

| PART NO. | Dimensions |       |
|----------|------------|-------|
|          | A          | B     |
| 4P       | 6.00       | 9.10  |
| 5P       | 8.00       | 11.10 |
| 6P       | 10.00      | 13.10 |
| 7P       | 12.00      | 15.10 |
| 8P       | 14.00      | 17.10 |
| 9P       | 16.00      | 19.10 |
| 10P      | 18.00      | 21.10 |
| 11P      | 20.00      | 23.10 |
| 12P      | 22.00      | 25.10 |
| 13P      | 24.00      | 27.10 |
| 14P      | 26.00      | 29.10 |
| 15P      | 28.00      | 31.10 |
| 16P      | 30.00      | 33.10 |
| 17P      | 32.00      | 35.10 |
| 18P      | 34.00      | 37.10 |
| 19P      | 36.00      | 39.10 |
| 20P      | 38.00      | 41.10 |

Unit: mm

### HDGC2008HB-XP

2.00mm pitch Housing

#### Reference Informations:

- \*Material:Nylon 66,UL94V-0
- \*Suitable HDGC2008-T-A series Terminal
- \*Mates with HDGC2008WV,WR,WV-S,WR-S-XP series Single Row Wafer or HDGC2008HM,HMB-XP series Single Row Housing or HDGC2008S-XP series Seal
- \*Color:White

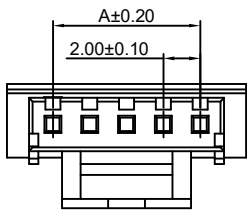

5P~16P

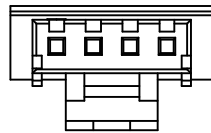

4P

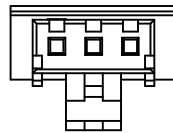

2P~3P

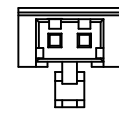

HDGC2008HD-2P

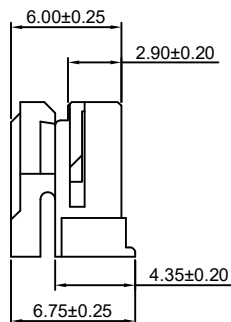
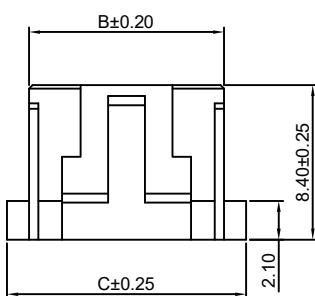
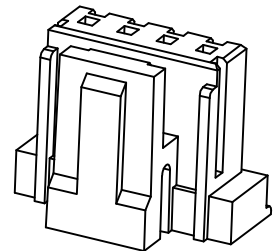

#### Ordering Information:

HDGC2008HB-XP - \*\*\* - \*\*  
1 2 3

- 1.Part No.
- 2.Material:  
(Blank):Nylon 66,UL94V-0  
GWT:Nylon 66,UL94V-0,GWT 750 °C
- 3.Color:  
(Blank):White  
BK:Black  
RD:Red  
YL:Yellow  
BL:Blue  
GN:Green  
GY:Gray

#### Ordering Information & Dimensions:

| PART NO. | Dimensions |       |       |
|----------|------------|-------|-------|
|          | A          | B     | C     |
| 2P       | 2.00       | 7.00  | 4.60  |
| 3P       | 4.00       | 9.00  | 6.60  |
| 4P       | 6.00       | 11.00 | 8.60  |
| 5P       | 8.00       | 13.00 | 10.60 |
| 6P       | 10.00      | 15.00 | 12.60 |
| 7P       | 12.00      | 17.00 | 14.60 |
| 8P       | 14.00      | 19.00 | 16.60 |
| 9P       | 16.00      | 21.00 | 18.60 |
| 10P      | 18.00      | 23.00 | 20.60 |
| 11P      | 20.00      | 25.00 | 22.60 |
| 12P      | 22.00      | 27.00 | 24.60 |
| 13P      | 24.00      | 29.00 | 26.60 |
| 14P      | 26.00      | 31.00 | 28.60 |
| 15P      | 28.00      | 33.00 | 30.60 |

Unit: mm



## HDGC2008 Series 2.00mm (.079") Pitch Wire to Board and Wire to Wire Connector

### HDGC2008HM-XP

2.00mm pitch Housing

**Reference Informations:**

- \*Material:Nylon 66,UL94V-0
- \*Suitable HDGC2008M-T series Terminal
- \*Mates with HDGC2008H,HB-XP series Single Row Housing
- \*Color:White

**Ordering Information:**

HDGC2008HM-XP -  $\frac{***}{1} - \frac{**}{2} - \frac{**}{3}$

- 1.Part No.
- 2.Material:  
(Blank):Nylon 66,UL94V-0  
GWT:Nylon 66,UL94V-0,GWT 750 °C
- 3.Color:  
(Blank):White  
BK:Black  
RD:Red  
YL:Yellow  
BL:Blue  
GN:Green  
GY:Gray

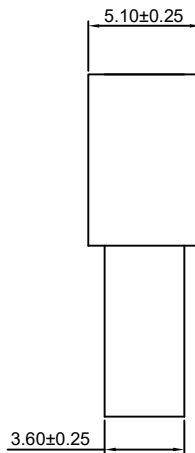
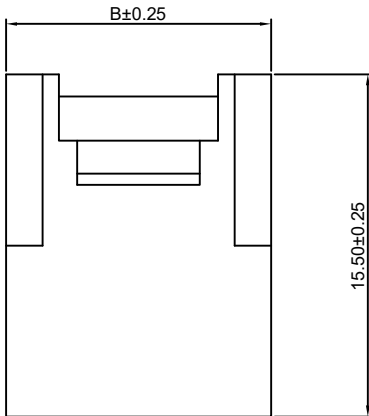
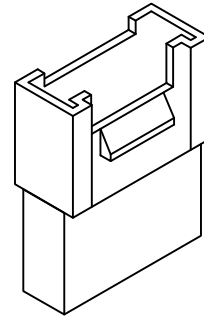
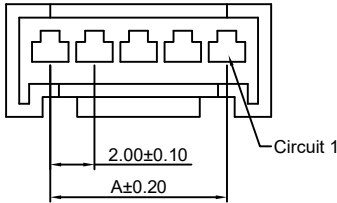

**Ordering Information & Dimensions:**

| PART NO. | Dimensions |       |
|----------|------------|-------|
|          | A          | B     |
| 2P       | 2.00       | 6.00  |
| 3P       | 4.00       | 8.00  |
| 4P       | 6.00       | 10.00 |
| 5P       | 8.00       | 12.00 |
| 6P       | 10.00      | 14.00 |
| 7P       | 12.00      | 16.00 |
| 8P       | 14.00      | 18.00 |
| 9P       | 16.00      | 20.00 |
| 10P      | 18.00      | 22.00 |
| 11P      | 20.00      | 24.00 |
| 12P      | 22.00      | 26.00 |
| 13P      | 24.00      | 28.00 |
| 14P      | 26.00      | 30.00 |
| 15P      | 28.00      | 32.00 |

Unit: mm

### HDGC2008HMB-XP

2.00mm pitch Housing

**Reference Informations:**

- \*Material:Nylon 66,UL94V-0
- \*Suitable HDGC2008M-T series Terminal
- \*Mates with HDGC2008H,HB-XP series Single Row Housing or HDGC2008S-XP series Seal
- \*Color:White

**Ordering Information:**

HDGC2008HMB-XP -  $\frac{***}{1} - \frac{**}{2} - \frac{**}{3}$

- 1.Part No.
- 2.Material:  
(Blank):Nylon 66,UL94V-0  
GWT:Nylon 66,UL94V-0,GWT 750 °C
- 3.Color:  
(Blank):White  
BK:Black  
RD:Red  
YL:Yellow  
BL:Blue  
GN:Green  
GY:Gray

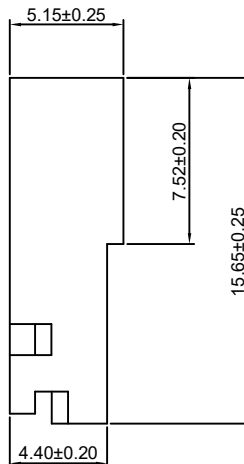
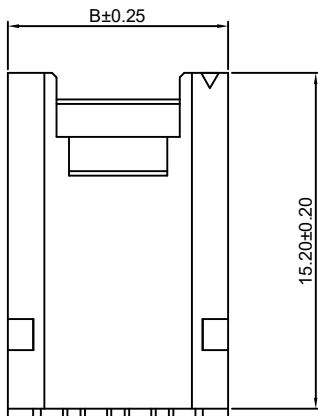
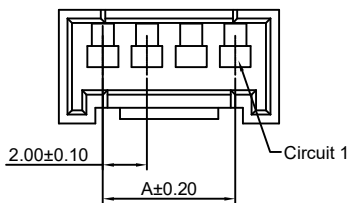

**Ordering Information & Dimensions:**

| PART NO. | Dimensions |       |
|----------|------------|-------|
|          | A          | B     |
| 2P       | 2.00       | 5.98  |
| 3P       | 4.00       | 7.98  |
| 4P       | 6.00       | 9.98  |
| 5P       | 8.00       | 11.98 |
| 6P       | 10.00      | 13.98 |
| 7P       | 12.00      | 15.98 |
| 8P       | 14.00      | 17.98 |
| 9P       | 16.00      | 19.98 |
| 10P      | 18.00      | 21.98 |
| 11P      | 20.00      | 23.98 |
| 12P      | 22.00      | 25.98 |
| 13P      | 24.00      | 27.98 |
| 14P      | 26.00      | 29.98 |
| 15P      | 28.00      | 31.98 |

Unit: mm



## HDGC2008 Series 2.00mm (.079") Pitch Wire to Board and Wire to Wire Connector

### HDGC2008H-2xXP

2.00mm pitch Dual Row Housing

**Reference Informations:**

- \*Material:Nylon 66,UL94V-0
- \*Suitable HDGC2008-T-A series Terminal
- \*Mates with HDGC2008WV,WR,WV-S-2xXP series Dual Row Wafer
- \*Color:White

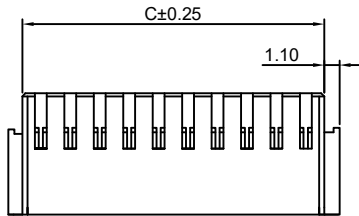
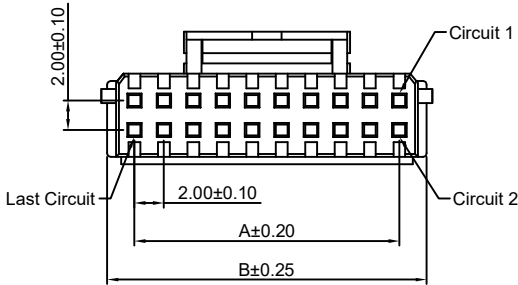

Ordering Information:  
HDGC2008H-2xXP - \*\*\*  
1 2

- 1.Part No.
- 2.Material:  
(Blank):Nylon 66,UL94V-0  
GWT:Nylon 66,UL94V-0,GWT 750 °C

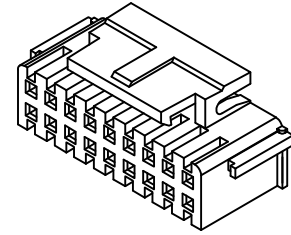

Ordering Information & Dimensions:

| PART NO. | Dimensions |       |       |
|----------|------------|-------|-------|
|          | A          | B     | C     |
| 2x2P     | 2.00       | 5.70  | 4.70  |
| 2x3P     | 4.00       | 7.70  | 6.70  |
| 2x4P     | 6.00       | 9.70  | 8.70  |
| 2x5P     | 8.00       | 11.70 | 10.70 |
| 2x6P     | 10.00      | 13.70 | 12.70 |
| 2x7P     | 12.00      | 15.70 | 14.70 |
| 2x8P     | 14.00      | 17.70 | 16.70 |
| 2x9P     | 16.00      | 19.70 | 18.70 |
| 2x10P    | 18.00      | 21.70 | 20.70 |
| 2x11P    | 20.00      | 23.70 | 22.70 |
| 2x12P    | 22.00      | 25.70 | 24.70 |
| 2x13P    | 24.00      | 27.70 | 26.70 |
| 2x14P    | 26.00      | 29.70 | 28.70 |
| 2x15P    | 28.00      | 31.70 | 30.70 |
| 2x16P    | 30.00      | 33.70 | 32.70 |
| 2x20P    | 38.00      | 41.70 | 40.70 |

Unit: mm

### HDGC2008WV-XP

2.00mm pitch 180° Wafer

**Reference Informations:**

- \*Material:Pin:Brass/Tin over Nickel  
Insulator:Nylon 66,UL94V-0
- \*Mates with HDGC2008H,HB-XP series Single Row Housing
- \*Color:White

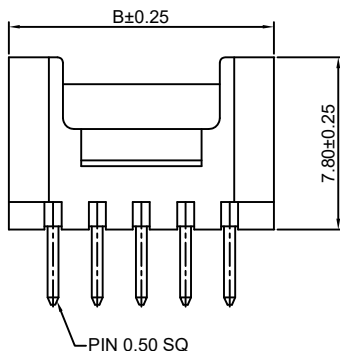
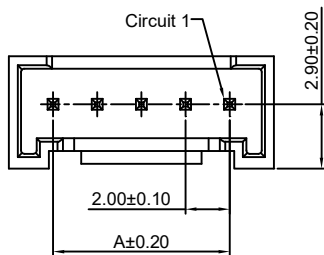

Ordering Information:  
HDGC2008WV-XP - \*\*\* - \*\* - \*\*  
1 2 3 4

- 1.Part No.
- 2.Material:  
(Blank):Nylon 66,UL94V-0  
GWT:Nylon 66,UL94V-0,GWT 750 °C
- 3.Color:  
(Blank):White  
BK:Black  
RD:Red  
YL:Yellow  
BL:Blue  
GN:Green  
GY:Gray
- 4.Finish:  
(Blank):Tin over Nickel  
G:Gold over Nickel

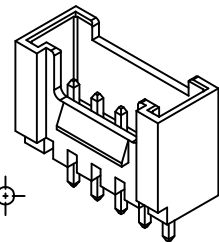
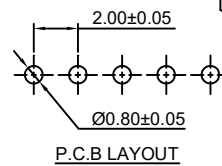

Ordering Information & Dimensions:

| PART NO. | Dimensions |       |
|----------|------------|-------|
|          | A          | B     |
| 2P       | 2.00       | 6.00  |
| 3P       | 4.00       | 8.00  |
| 4P       | 6.00       | 10.00 |
| 5P       | 8.00       | 12.00 |
| 6P       | 10.00      | 14.00 |
| 7P       | 12.00      | 16.00 |
| 8P       | 14.00      | 18.00 |
| 9P       | 16.00      | 20.00 |
| 10P      | 18.00      | 22.00 |
| 11P      | 20.00      | 24.00 |
| 12P      | 22.00      | 26.00 |
| 13P      | 24.00      | 28.00 |
| 14P      | 26.00      | 30.00 |
| 15P      | 28.00      | 32.00 |
| 16P      | 30.00      | 34.00 |

Unit: mm



## HDGC2008 Series 2.00mm (.079") Pitch Wire to Board and Wire to Wire Connector

### HDGC2008WR-XP

2.00mm pitch 90° Wafer

**Reference Informations:**

- \*Material:Pin:Brass/Tin over Nickel  
Insulator:Nylon 66,UL94V-0
- \*Mates with HDGC2008H,HB-XP series Single Row Housing
- \*Color:White

Ordering Information:  
HDGC2008WR-XP -  $\frac{***}{1} - \frac{**}{2} - \frac{**}{3} - \frac{**}{4}$

- Part No.
- Material:  
(Blank):Nylon 66,UL94V-0  
GWT:Nylon 66,UL94V-0,GWT 750 °C
- Color:  
(Blank):White  
BK:Black  
RD:Red  
YL:Yellow  
BL:Blue  
GN:Green  
GY:Gray
- Finish:  
(Blank):Tin over Nickel  
G:Gold over Nickel

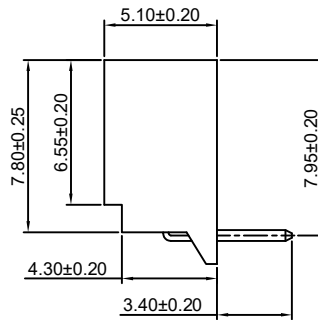
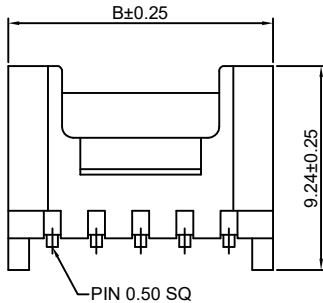
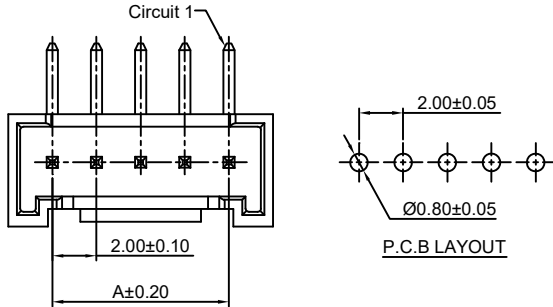
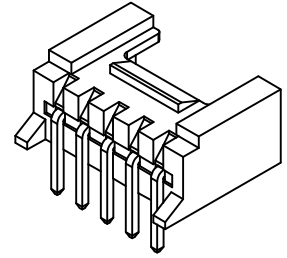

**Ordering Information & Dimensions:**

| PART NO. | Dimensions |       |
|----------|------------|-------|
|          | A          | B     |
| 2P       | 2.00       | 6.00  |
| 3P       | 4.00       | 8.00  |
| 4P       | 6.00       | 10.00 |
| 5P       | 8.00       | 12.00 |
| 6P       | 10.00      | 14.00 |
| 7P       | 12.00      | 16.00 |
| 8P       | 14.00      | 18.00 |
| 9P       | 16.00      | 20.00 |
| 10P      | 18.00      | 22.00 |
| 11P      | 20.00      | 24.00 |
| 12P      | 22.00      | 26.00 |
| 13P      | 24.00      | 28.00 |
| 14P      | 26.00      | 30.00 |
| 15P      | 28.00      | 32.00 |
| 16P      | 30.00      | 34.00 |

Unit: mm

### HDGC2008WVA-XP

2.00mm pitch 180° Wafer

**Reference Informations:**

- \*Material:Pin:Brass/Tin over Nickel  
Insulator:Nylon 66,UL94V-0
- \*Mates with HDGC2008HA-XP series Single Row Housing
- \*Color:Ivory

Ordering Information:  
HDGC2008WVA-XP -  $\frac{***}{1} - \frac{**}{2} - \frac{**}{3} - \frac{**}{4}$

- Part No.
- Material:  
(Blank):Nylon 66,UL94V-0  
GWT:Nylon 66,UL94V-0,GWT 750 °C
- Color:  
(Blank):White  
BK:Black  
RD:Red  
YL:Yellow  
BL:Blue  
GN:Green  
GY:Gray
- Finish:  
(Blank):Tin over Nickel  
G:Gold over Nickel

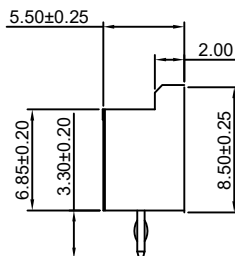
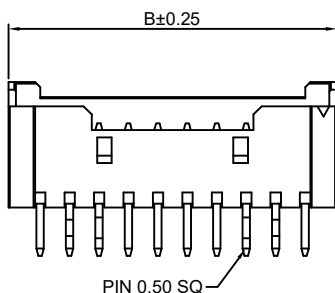
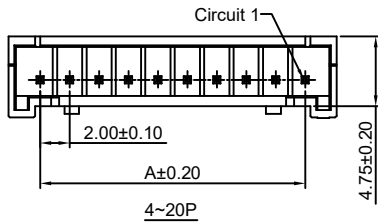
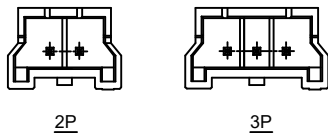
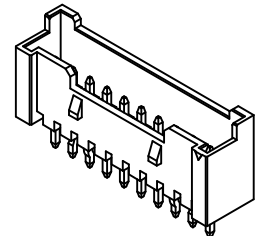
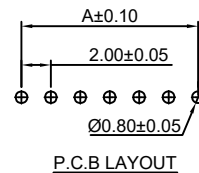

**Ordering Information & Dimensions:**

| PART NO. | Dimensions |       |
|----------|------------|-------|
|          | A          | B     |
| 2P       | 2.00       | 7.70  |
| 3P       | 4.00       | 9.70  |
| 4P       | 6.00       | 10.30 |
| 5P       | 8.00       | 12.30 |
| 6P       | 10.00      | 14.30 |
| 7P       | 12.00      | 16.30 |
| 8P       | 14.00      | 18.30 |
| 9P       | 16.00      | 20.30 |
| 10P      | 18.00      | 22.30 |
| 11P      | 20.00      | 24.30 |
| 12P      | 22.00      | 26.30 |
| 13P      | 24.00      | 28.30 |
| 14P      | 26.00      | 30.30 |
| 15P      | 28.00      | 32.30 |
| 16P      | 30.00      | 34.30 |
| 17P      | 32.00      | 36.30 |
| 18P      | 34.00      | 38.30 |
| 19P      | 36.00      | 40.30 |
| 20P      | 38.00      | 42.30 |

Unit: mm



## HDGC2008 Series 2.00mm (.079") Pitch Wire to Board and Wire to Wire Connector

### HDGC2008WRA-XP

2.00mm pitch 90° Wafer

**Reference Informations:**

- \*Material: Pin: Brass/Tin over Nickel  
Insulator: Nylon 66, UL94V-0
- \*Mates with HDGC2008HA-XP series Single Row Housing
- \*Color: Ivory

Ordering Information:  
HDGC2008WRA-XP - <sup>\*\*\*</sup> - <sup>\*\*</sup> - <sup>\*\*</sup>

1. Part No.
2. Material:  
(Blank): Nylon 66, UL94V-0  
GWT: Nylon 66, UL94V-0, GWT 750 °C
3. Color:  
(Blank): White  
BK: Black  
RD: Red  
YL: Yellow  
BL: Blue  
GN: Green  
GY: Gray
4. Finish:  
(Blank): Tin over Nickel  
G: Gold over Nickel

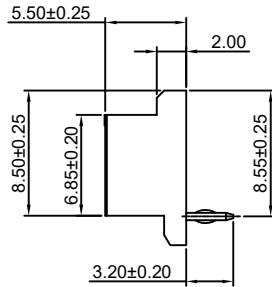
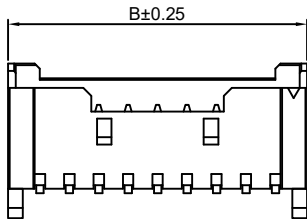
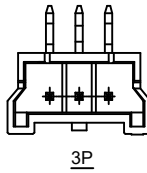
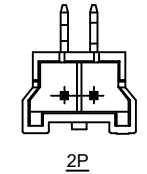
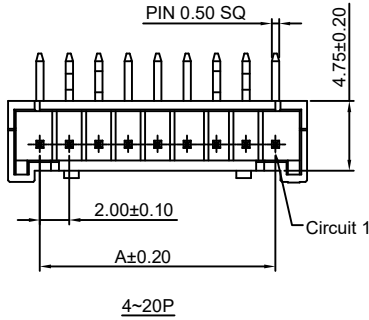
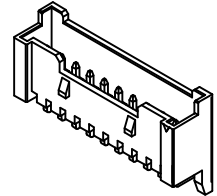
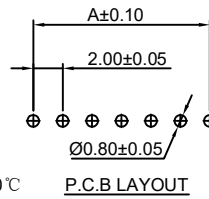

**Ordering Information & Dimensions:**

| PART NO. | Dimensions |       |
|----------|------------|-------|
|          | A          | B     |
| 2P       | 2.00       | 7.70  |
| 3P       | 4.00       | 9.70  |
| 4P       | 6.00       | 10.30 |
| 5P       | 8.00       | 12.30 |
| 6P       | 10.00      | 14.30 |
| 7P       | 12.00      | 16.30 |
| 8P       | 14.00      | 18.30 |
| 9P       | 16.00      | 20.30 |
| 10P      | 18.00      | 22.30 |
| 11P      | 20.00      | 24.30 |
| 12P      | 22.00      | 26.30 |
| 13P      | 24.00      | 28.30 |
| 14P      | 26.00      | 30.30 |
| 15P      | 28.00      | 32.30 |
| 16P      | 30.00      | 34.30 |
| 17P      | 32.00      | 36.30 |
| 18P      | 34.00      | 38.30 |
| 19P      | 36.00      | 40.30 |
| 20P      | 38.00      | 42.30 |

Unit: mm

### HDGC2008WV-2xXP

2.00mm pitch 180° Dual Row Wafer

**Reference Informations:**

- \*Material: Pin: Brass/Tin over Nickel  
Insulator: Nylon 66, UL94V-0
- \*Mates with HDGC2008H-2xXP series Dual Row Housing
- \*Color: Ivory

Ordering Information:  
HDGC2008WV-2xXP - <sup>\*\*\*</sup> - <sup>\*\*</sup>

1. Part No.
2. Material:  
(Blank): Nylon 66, UL94V-0  
GWT: Nylon 66, UL94V-0, GWT 750 °C
3. Finish:  
(Blank): Tin over Nickel  
G: Gold over Nickel

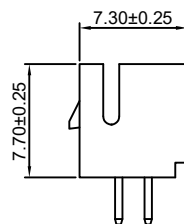
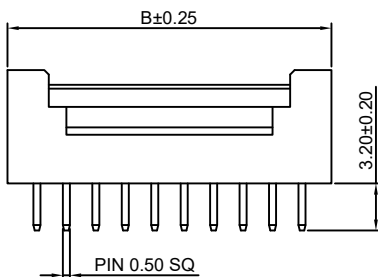
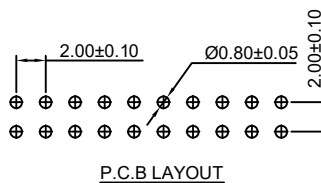
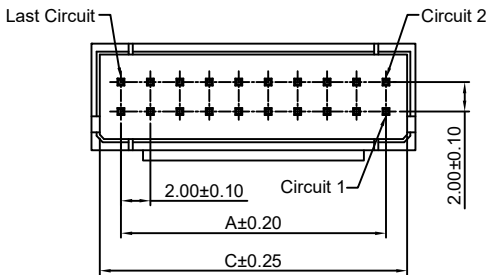
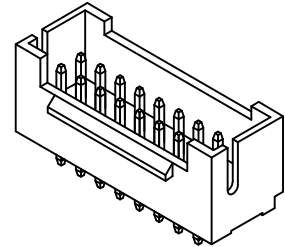

**Ordering Information & Dimensions:**

| PART NO. | Dimensions |       |       |
|----------|------------|-------|-------|
|          | A          | B     | C     |
| 2x2P     | 2.00       | 6.00  | 4.80  |
| 2x3P     | 4.00       | 8.00  | 6.80  |
| 2x4P     | 6.00       | 10.00 | 8.80  |
| 2x5P     | 8.00       | 12.00 | 10.80 |
| 2x6P     | 10.00      | 14.00 | 12.80 |
| 2x7P     | 12.00      | 16.00 | 14.80 |
| 2x8P     | 14.00      | 18.00 | 16.80 |
| 2x9P     | 16.00      | 20.00 | 18.80 |
| 2x10P    | 18.00      | 22.00 | 20.80 |
| 2x11P    | 20.00      | 24.00 | 22.80 |
| 2x12P    | 22.00      | 26.00 | 24.80 |
| 2x13P    | 24.00      | 28.00 | 26.80 |
| 2x14P    | 26.00      | 30.00 | 28.80 |
| 2x15P    | 28.00      | 32.00 | 30.80 |
| 2x16P    | 30.00      | 34.00 | 32.80 |
| 2x20P    | 38.00      | 42.00 | 40.80 |

Unit: mm





### HDGC2008WR-2xXP

2.00mm pitch 90° Dual Row Wafer

#### Reference Informations:

- \*Material:Pin:Brass/Tin over Nickel  
Insulator:Nylon 66,UL94V-0
- \*Mates with HDGC2008H-2xXP series Dual Row Housing
- \*Color:Ivory

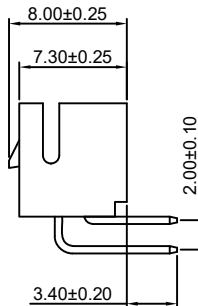
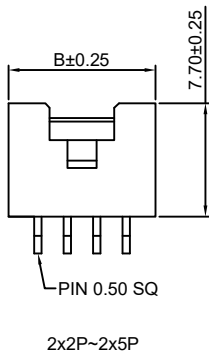
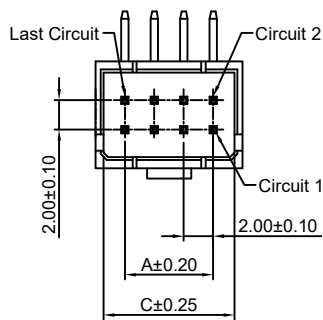
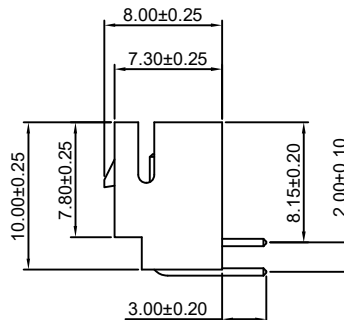
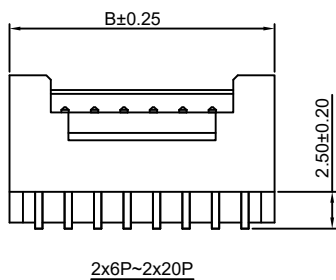
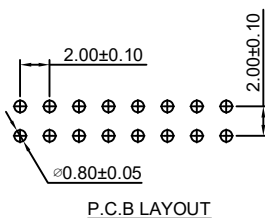
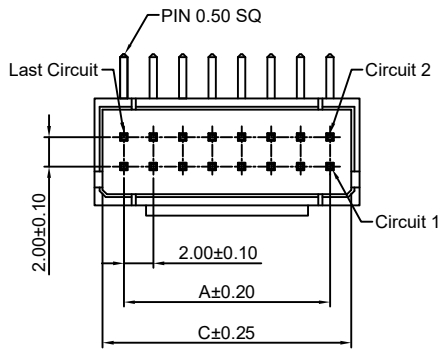
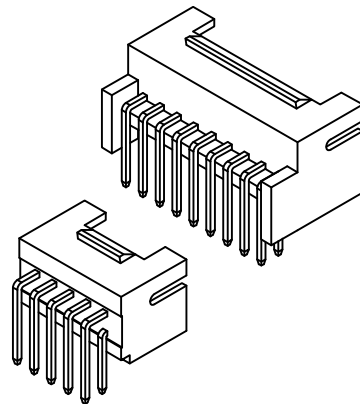

#### Ordering Information:

HDGC2008WR-2xXP - <sup>\*\*\*</sup>/<sub>2</sub> - <sup>\*\*</sup>/<sub>3</sub>

- Part No.
- Material:  
(Blank):Nylon 66,UL94V-0  
GWT:Nylon 66,UL94V-0,GWT 750 °C
- Finish:  
(Blank):Tin over Nickel  
G:Gold over Nickel

#### Ordering Information & Dimensions:

| PART NO. | Dimensions |       |       |
|----------|------------|-------|-------|
|          | A          | B     | C     |
| 2x2P     | 2.00       | 6.00  | 4.80  |
| 2x3P     | 4.00       | 8.00  | 6.80  |
| 2x4P     | 6.00       | 10.00 | 8.80  |
| 2x5P     | 8.00       | 12.00 | 10.80 |
| 2x6P     | 10.00      | 14.00 | 12.80 |
| 2x7P     | 12.00      | 16.00 | 14.80 |
| 2x8P     | 14.00      | 18.00 | 16.80 |
| 2x9P     | 16.00      | 20.00 | 18.80 |
| 2x10P    | 18.00      | 22.00 | 20.80 |
| 2x11P    | 20.00      | 24.00 | 22.80 |
| 2x12P    | 22.00      | 26.00 | 24.80 |
| 2x13P    | 24.00      | 28.00 | 26.80 |
| 2x14P    | 26.00      | 30.00 | 28.80 |
| 2x15P    | 28.00      | 32.00 | 30.80 |
| 2x16P    | 30.00      | 34.00 | 32.80 |
| 2x20P    | 38.00      | 42.00 | 40.80 |

Unit: mm



## HDGC2008 Series 2.00mm (.079") Pitch Wire to Board and Wire to Wire Connector

### HDGC2008WV-S-XP

2.00mm pitch 180° Wafer-SMT TYPE

**Reference Informations:**

- \*Material: Pin: Brass/Tin over Nickel  
Insulator: Nylon 6T, UL94V-0
- \*Mates with HDGC2008H, HB-XP series Single Row Housing
- \*Color: Ivory

**Ordering Information:**

HDGC2008WV-S-XP -  $\frac{***}{1} - \frac{**}{2} - \frac{**}{3} - \frac{**}{4}$

- Part No.
- Material:  
(Blank): Nylon 6T, UL94V-0  
GWT: Nylon 6T, UL94V-0, GWT 750 °C
- Color:  
(Blank): White  
BK: Black  
RD: Red  
YL: Yellow  
BL: Blue  
GN: Green  
GY: Gray
- Finish:  
(Blank): Tin over Nickel  
G: Gold over Nickel

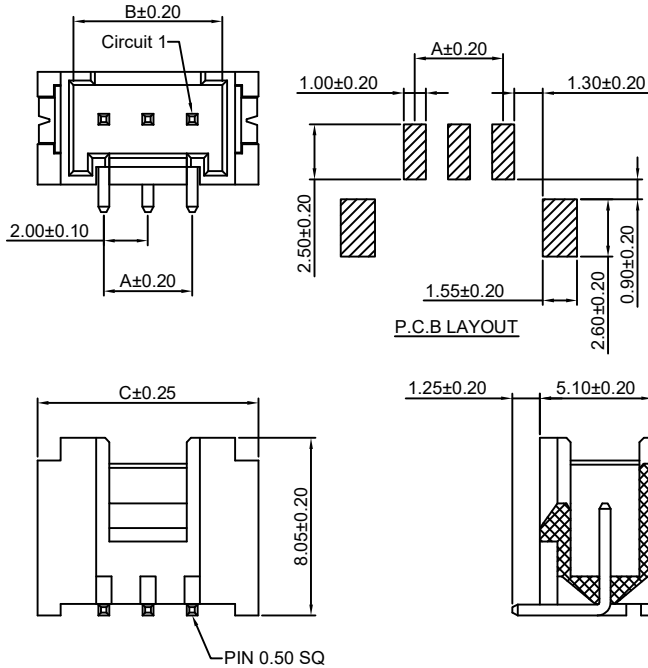
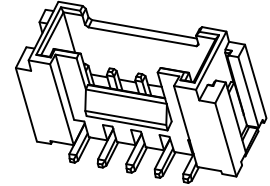

**Ordering Information & Dimensions:**

| PART NO. | Dimensions |       |       |
|----------|------------|-------|-------|
|          | A          | B     | C     |
| 2P       | 2.00       | 4.75  | 8.00  |
| 3P       | 4.00       | 6.75  | 10.00 |
| 4P       | 6.00       | 8.75  | 12.00 |
| 5P       | 8.00       | 10.75 | 14.00 |
| 6P       | 10.00      | 12.75 | 16.00 |
| 7P       | 12.00      | 14.75 | 18.00 |
| 8P       | 14.00      | 16.75 | 20.00 |
| 9P       | 16.00      | 18.75 | 22.00 |
| 10P      | 18.00      | 20.75 | 24.00 |
| 11P      | 20.00      | 22.75 | 26.00 |
| 12P      | 22.00      | 24.75 | 28.00 |
| 13P      | 24.00      | 26.75 | 30.00 |
| 14P      | 26.00      | 28.75 | 32.00 |
| 15P      | 28.00      | 30.75 | 34.00 |
| 16P      | 30.00      | 32.75 | 36.00 |

Unit: mm

### HDGC2008WR-S-XP

2.00mm pitch 90° Wafer-SMT TYPE

**Reference Informations:**

- \*Material: Pin: Brass/Tin over Nickel  
Insulator: Nylon 6T, UL94V-0
- \*Mates with HDGC2008H, HB-XP series Single Row Housing
- \*Color: Beige

**Ordering Information:**

HDGC2008WR-S-XP -  $\frac{***}{1} - \frac{**}{2} - \frac{**}{3} - \frac{**}{4}$

- Part No.
- Material:  
(Blank): Nylon 6T, UL94V-0  
GWT: Nylon 6T, UL94V-0, GWT 750 °C
- Color:  
(Blank): White  
BK: Black  
RD: Red  
YL: Yellow  
BL: Blue  
GN: Green  
GY: Gray
- Finish:  
(Blank): Tin over Nickel  
G: Gold over Nickel

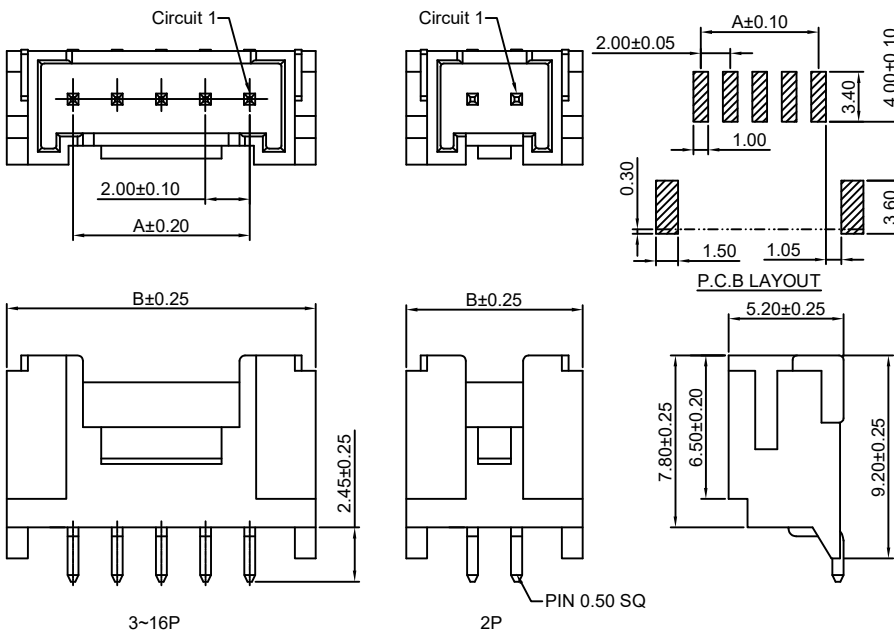
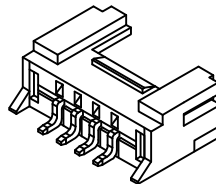

**Ordering Information & Dimensions:**

| PART NO. | Dimensions |       |
|----------|------------|-------|
|          | A          | B     |
| 2P       | 2.00       | 8.00  |
| 3P       | 4.00       | 10.00 |
| 4P       | 6.00       | 12.00 |
| 5P       | 8.00       | 14.00 |
| 6P       | 10.00      | 16.00 |
| 7P       | 12.00      | 18.00 |
| 8P       | 14.00      | 20.00 |
| 9P       | 16.00      | 22.00 |
| 10P      | 18.00      | 24.00 |
| 11P      | 20.00      | 26.00 |
| 12P      | 22.00      | 28.00 |
| 13P      | 24.00      | 30.00 |
| 14P      | 26.00      | 32.00 |
| 15P      | 28.00      | 34.00 |
| 16P      | 30.00      | 36.00 |

Unit: mm



## HDGC2008 Series 2.00mm (.079") Pitch Wire to Board and Wire to Wire Connector

### HDGC2008WV-S-2xXP

2.00mm pitch 180° Dual Row Wafer-SMT TYPE

#### Reference Informations:

- \*Material: Pin: Brass/Tin over Nickel  
Insulator: Nylon 6T, UL94V-0
- \*Mates with HDGC2008H-2xXP series Dual Row Housing
- \*Color: Ivory

#### Ordering Information:

HDGC2008WV-S-2xXP - \*\*\* - \*\*  
1 2 3

- Part No.
- Material:  
(Blank): Nylon 6T, UL94V-0  
GWT: Nylon 6T, UL94V-0, GWT 750 °C
- Finish:  
(Blank): Tin over Nickel  
G: Gold over Nickel

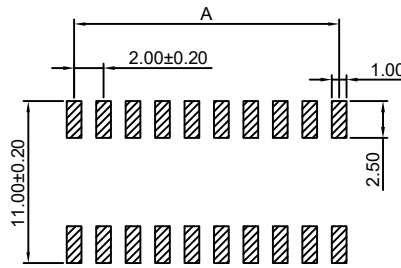
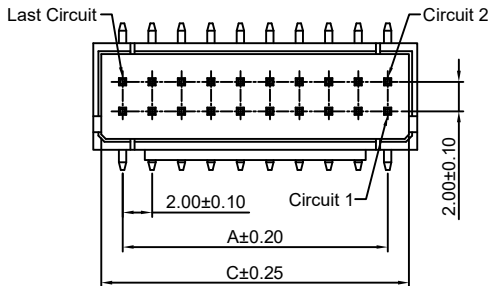
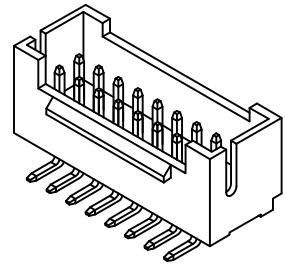

P.C.B LAYOUT

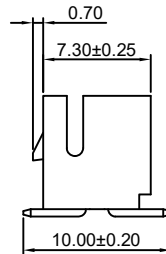
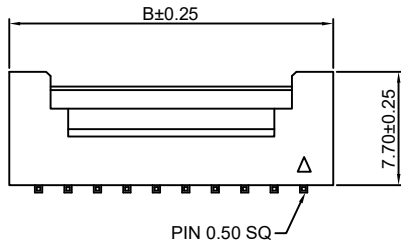

#### Ordering Information & Dimensions:

| PART NO. | Dimensions |       |       |
|----------|------------|-------|-------|
|          | A          | B     | C     |
| 2x2P     | 2.00       | 6.00  | 4.80  |
| 2x3P     | 4.00       | 8.00  | 6.80  |
| 2x4P     | 6.00       | 10.00 | 8.80  |
| 2x5P     | 8.00       | 12.00 | 10.80 |
| 2x6P     | 10.00      | 14.00 | 12.80 |
| 2x7P     | 12.00      | 16.00 | 14.80 |
| 2x8P     | 14.00      | 18.00 | 16.80 |
| 2x9P     | 16.00      | 20.00 | 18.80 |
| 2x10P    | 18.00      | 22.00 | 20.80 |
| 2x11P    | 20.00      | 24.00 | 22.80 |
| 2x12P    | 22.00      | 26.00 | 24.80 |
| 2x13P    | 24.00      | 28.00 | 26.80 |
| 2x14P    | 26.00      | 30.00 | 28.80 |
| 2x15P    | 28.00      | 32.00 | 30.80 |
| 2x16P    | 30.00      | 34.00 | 32.80 |
| 2x20P    | 38.00      | 42.00 | 40.80 |

Unit: mm

### HDGC2008S-XP

2.00mm pitch Seal

#### Reference Informations:

- \*Material: Nylon 66, UL94V-2
- \*Use in HDGC2008HB, HMB-XP series Housing
- \*Color: Brick red

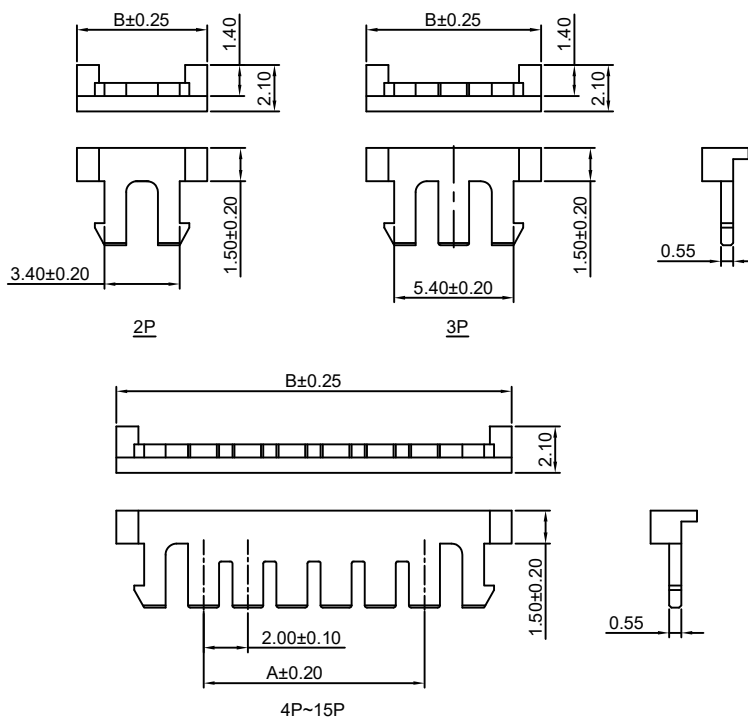

#### Ordering Information:

HDGC2008S-XP - \*\*\*  
1 2

- Part No.
- Material:  
(Blank): Nylon 66, UL94V-2  
GWT: Nylon 66, UL94V-0, GWT 750 °C

#### Ordering Information & Dimensions:

| PART NO. | Dimensions |       |
|----------|------------|-------|
|          | A          | B     |
| 2P       | 3.40       | 5.90  |
| 3P       | 5.40       | 7.90  |
| 4P       | 7.40       | 9.90  |
| 5P       | 9.40       | 11.90 |
| 6P       | 11.40      | 13.90 |
| 7P       | 13.40      | 15.90 |
| 8P       | 15.40      | 17.90 |
| 9P       | 17.40      | 19.90 |
| 10P      | 19.40      | 21.90 |
| 11P      | 21.40      | 23.90 |
| 12P      | 23.40      | 25.90 |
| 13P      | 25.40      | 27.90 |
| 14P      | 27.40      | 29.90 |
| 15P      | 29.40      | 31.90 |

Unit: mm