

修订 REV	标记 MARK	修改摘要 REVISION DESCRIPTION	签名 SIGNATURE	日期 DATE
AO		NEW RELEASE	WANG	2013-11-03

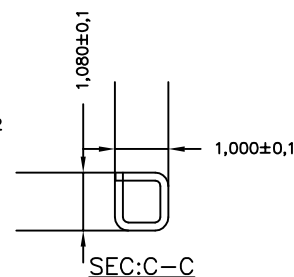
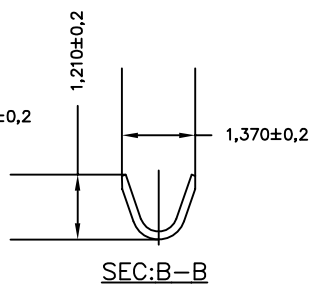
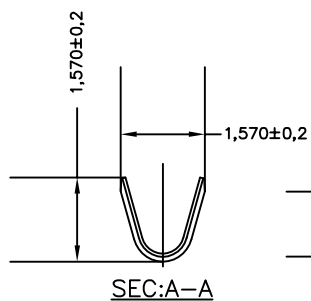
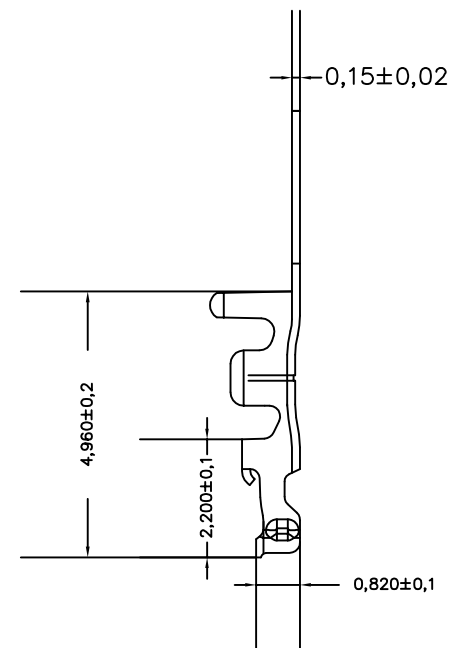
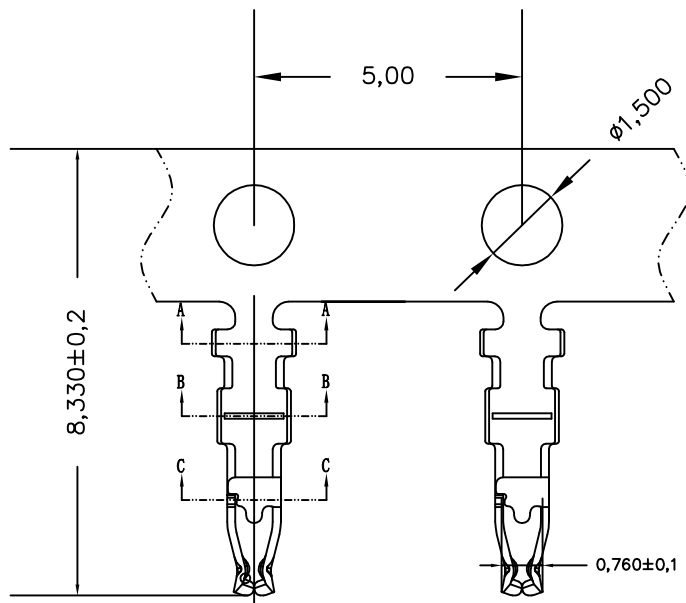

Ordering Information & Specifications

Part No	Wire Range	Insulation O.D.	Material	Finish	Qty/reel
HDGC1255-T	AWG#26-#32	1.00mm(max)	Phosphor Bronze	Tin-platde	17,000pcs

要求:

- 1、材质: 磷铜C5191, 材厚 0.15 ± 0.02 mm;
- 2、电镀: 先冲后镀, 镀全锡。

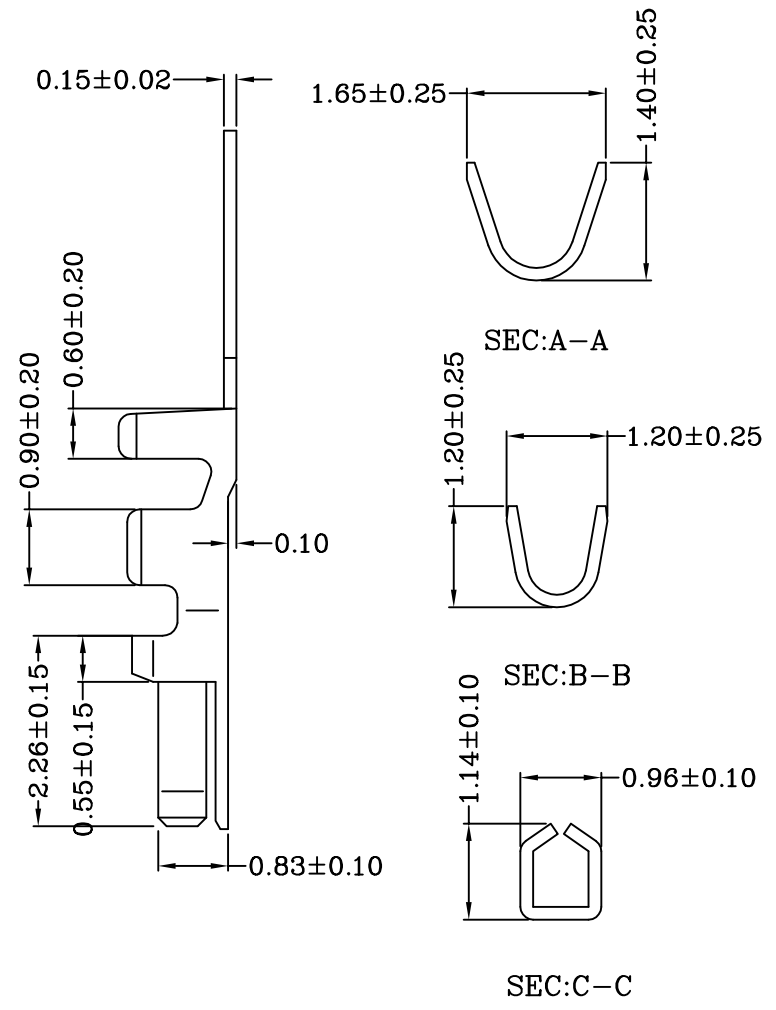
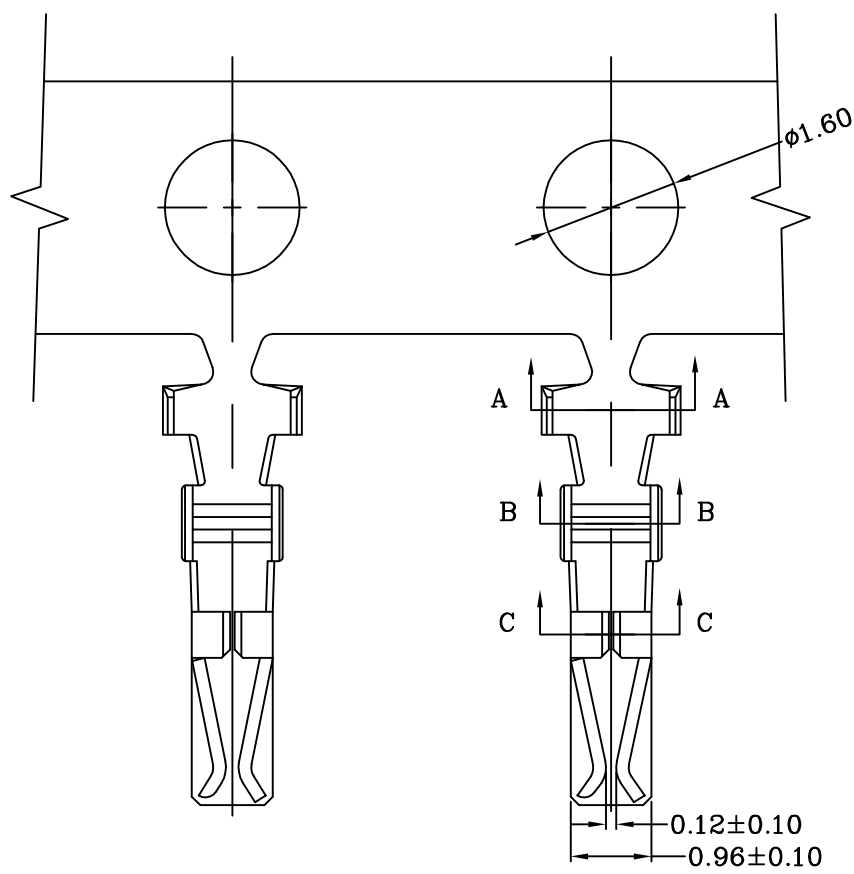

 深圳市华德共创科技有限公司 Shenzhen Huade co-create Technology Co.,LTD TEL : 0755-27129737 FAX : 0755-29940187				TITLE: 1.25mm Pitch 产品名称: Crimp Terminal					
-TOLERANCES- UNLESS OTHERWISE SPECIFIED 公差参数表				 		PART NO: 产品编号: HDGC1255-T			
X.X	±0.30	X.X°	±3°	APPD: 核准:	XIE	DATE	SCALE	UNIT	CODE NUMBER
X.XX	±0.30	X.XX°	±2°	CHECK: 校对:	WANG	2013-11-03	1:1	mm	A001
X.XXX	±0.10	X.XXX°	±1°	DRAW: 绘图:	WANG				

修订 REV	标记 MARK	修改摘要 REVISION DESCRIPTION	签名 SIGNATURE	日期 DATE
AO		NEW RELEASE	WANG	2011-04-09



产品要求:

- 1、材质：磷铜C5191，材厚 $T=0.15 \pm 0.02\text{mm}$ ；
- 2、电镀：先冲后镀，镀全锡。

		深圳市华德共创科技有限公司 Shenzhen Huade co-create Technology Co.,LTD TEL : 0755-27129737 FAX : 0755-29940187						
-TOLERANCES- UNLESS OTHERWISE SPECIFIED 公差参数表		 		TITLE: 1.25mm Pitch 产品名称: Crimp Terminal				
X.X	± 0.30	X.X°	$\pm 3^\circ$	APPD: 核准: XIE	PART NO: 产品编号: HDGC1255-T-B			
X.XX	± 0.30	X.XX°	$\pm 2^\circ$	CHECK: 校对: WANG	DATE	SCALE	UNIT	CODE NUMBER
X.XXX	± 0.10	X.XXX°	$\pm 1^\circ$	DRAW: 绘图: WANG	2011-04-09	1:1	mm	A001

修订 REV	标记 MARK	修改摘要 REVISION DESCRIPTION	签名 SIGNATURE	日期 DATE
AO		NEW RELEASE	WANG	2013-06-07

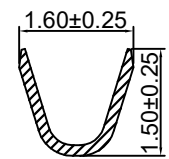
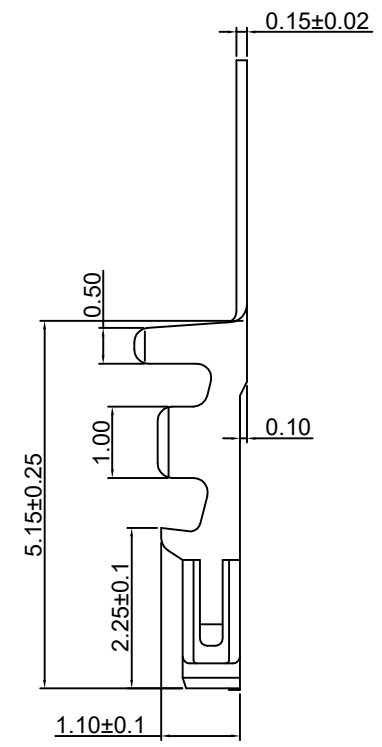
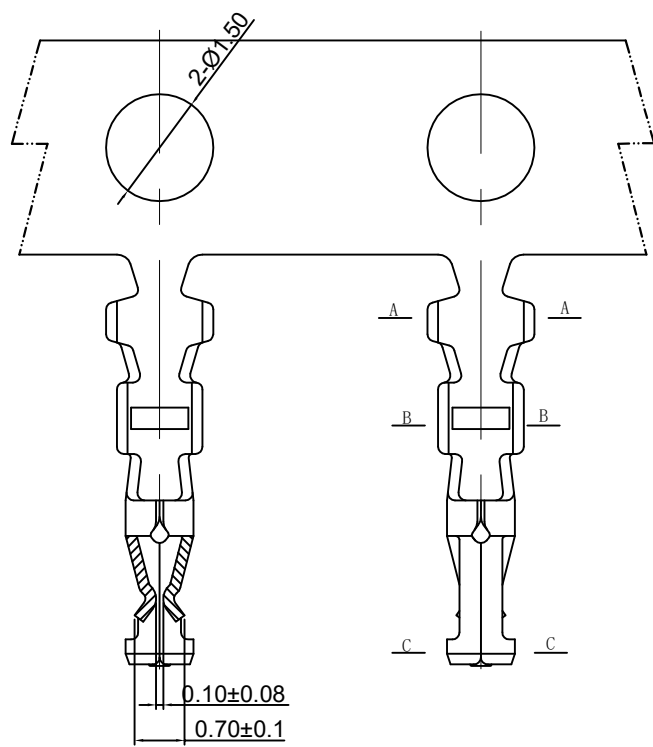

A-A

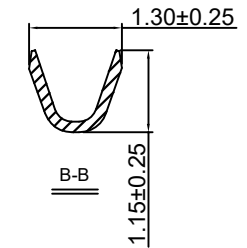

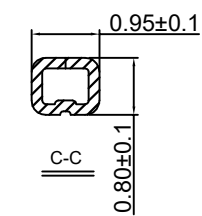

B-B



C-C

Notes:
1. MATERIAL: 0.150 mm PHOSPHOR BRONZE,C5191

		深圳市华德共创科技有限公司 Shenzhen Huade co-create Technology Co.,LTD TEL : 0755-27129737 FAX : 0755-29940187						
-TOLERANCES- UNLESS OTHERWISE SPECIFIED 公差参数表			 		TITLE: 1.25mm Pitch 产品名称: Crimp Terminal			
X.X	±0.30	X.X°	±3°	APPD: 核准:	PART NO: 产品编号: HDGC1255-T-C			
X.XX	±0.30	X.XX°	±2°	CHECK: 校对:	DATE	SCALE	UNIT	CODE NUMBER
X.XXX	±0.10	X.XXX°	±1°	DRAW: 绘图:	2013-06-07	1:1	mm	A001

修订 REV	标记 MARK	修改摘要 REVISION DESCRIPTION	签名 SIGNATURE	日期 DATE
AO		NEW RELEASE	WANG	2016-05-10

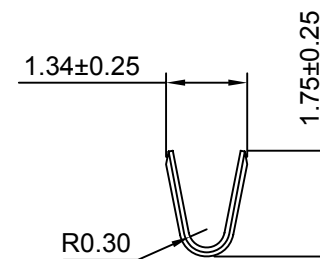
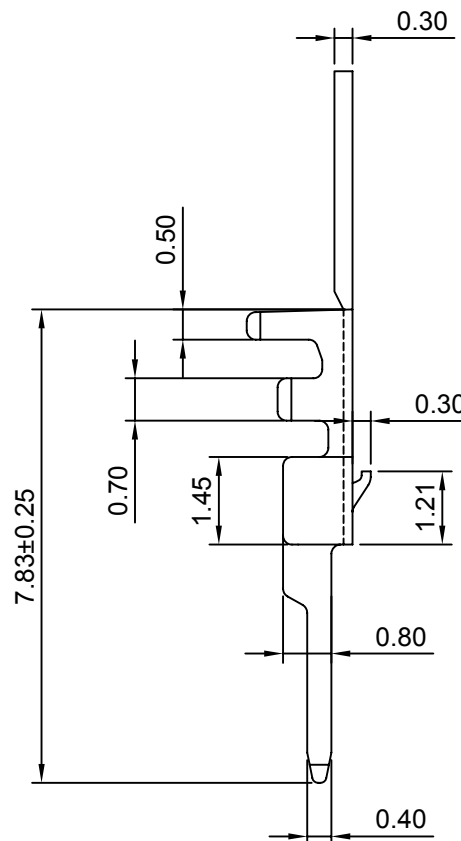
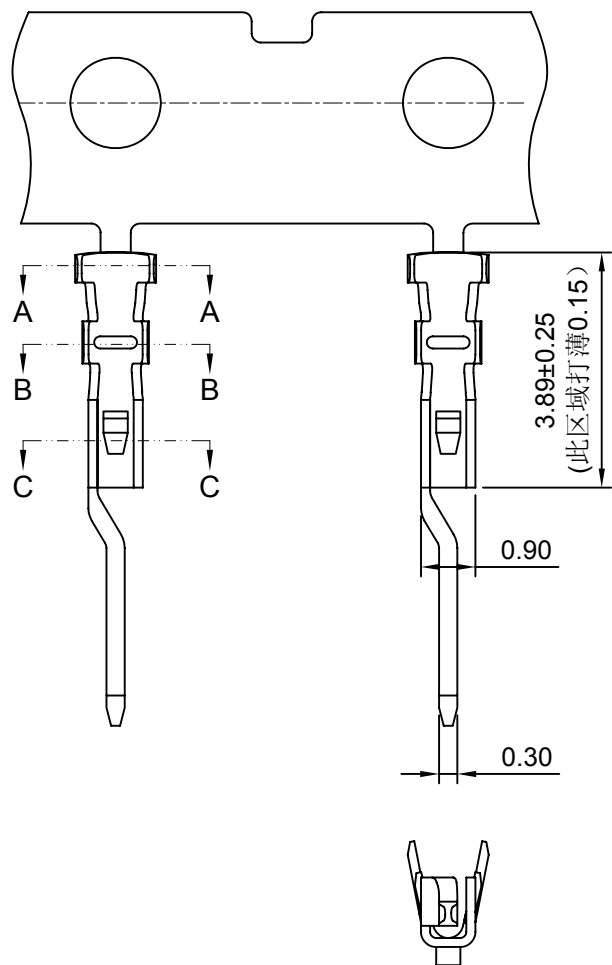

SEC:A-A

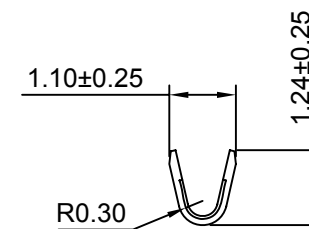

SEC:B-B

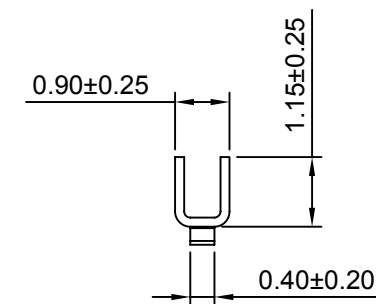

SEC:C-C

Ordering information & Specifications

Unit:mm

Part No	Wire Range	Insultion O.D.	Material	Finish	Qty/reel
HDGC1255MA-TP	AWG#28-#32	0.90mm(max)	Phosphor Bronze	Tin over Nickel	15,000 PCS
HDGC1255MA-GP	AWG#28-#32	0.90mm(max)	Phosphor Bronze	Gold over Nickel	15,000 PCS

Optional Gold plating available but MOQ requested



深圳市华德共创科技有限公司

Shenzhen Huade co-create Technology Co.,LTD

TEL : 0755-27129737 FAX : 0755-29940187

-TOLERANCES- UNLESS OTHERWISE SPECIFIED 公差参数表					TITLE: 1.25mm Pitch 产品名称: Crimp Terminal			
X.X	± 0.30	X.X°	$\pm 3^\circ$	APPD: 核准: XIE	PART NO: 产品编号: HDGC1255MA-T			
X.XX	± 0.30	X.XX°	$\pm 2^\circ$	CHECK: 校对: WANG	DATE	SCALE	UNIT	CODE NUMBER
X.XXX	± 0.10	X.XXX°	$\pm 1^\circ$	DRAW: 绘图: WANG	2016-05-10	3:1	mm	A008

修订 REV	标记 MARK	修改摘要 REVISION DESCRIPTION	签名 SIGNATURE	日期 DATE
AO		NEW RELEASE	WANG	2013-05-07

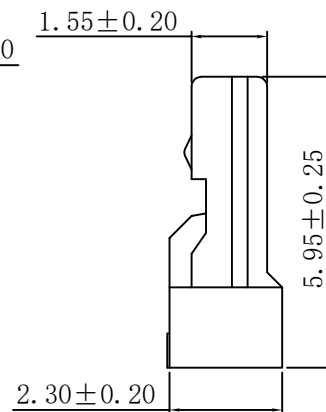
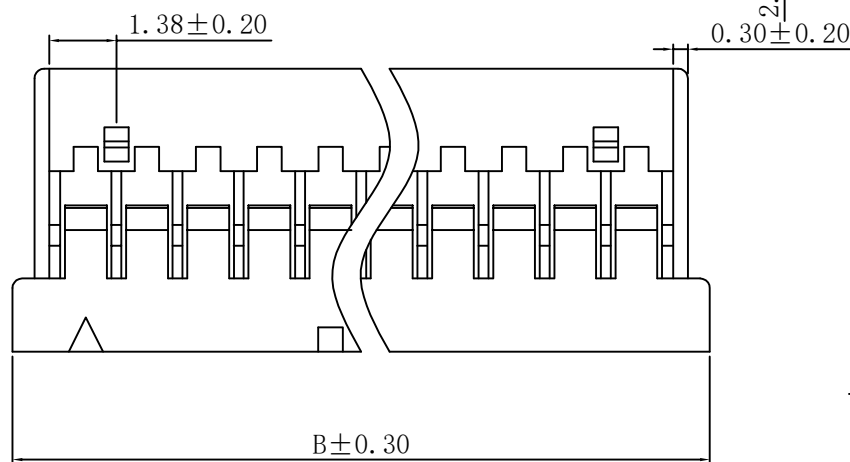
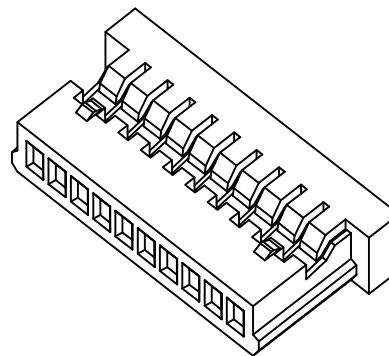
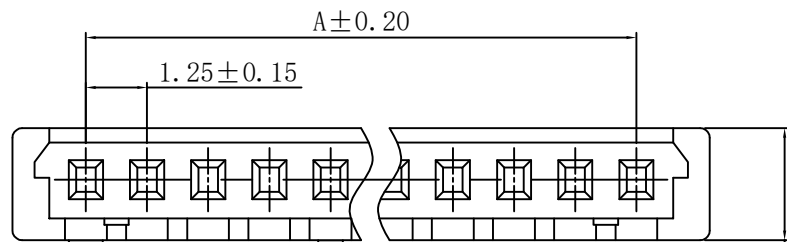

PART NO.	Dimensions	
	A	B
HDGC1255H-2P	1.25	4.25
HDGC1255H-3P	2.50	5.50
HDGC1255H-4P	3.75	6.75
HDGC1255H-5P	5.00	8.00
HDGC1255H-6P	6.25	9.25
HDGC1255H-7P	7.50	10.50
HDGC1255H-8P	8.75	11.75
HDGC1255H-9P	10.00	13.00
HDGC1255H-10P	11.25	14.25
HDGC1255H-11P	12.50	15.50
HDGC1255H-12P	13.75	16.75
HDGC1255H-13P	15.00	18.00
HDGC1255H-14P	16.25	19.25
HDGC1255H-15P	17.50	20.50
HDGC1255H-20P	23.75	26.75
HDGC1255H-21P	25.00	28.00
HDGC1255H-25P	30.00	33.00
HDGC1255H-30P	36.25	39.25



深圳市华德共创科技有限公司

Shenzhen Huade co-create Technology Co.,LTD

TEL : 0755-27129737 FAX : 0755-29940187

-TOLERANCES- UNLESS OTHERWISE SPECIFIED 公差参数表				 	TITLE: 产品名称 : 1.25mm Pitch Housing			
X.X	±0.30	X.X°	±3°	APPD: 核准 : XIE	PART NO: 产品编号 : HDGC1255H-XP			
X.XX	±0.30	X.XX°	±2°	CHECK: 校对 : WANG	DATE	SCALE	UNIT	CODE NUMBER
X.XXX	±0.10	X.XXX°	±1°	DRAW: 绘图 : WANG	2013-05-07	1:1	mm	A008

修订 REV	标记 MARK	修改摘要 REVISION DESCRIPTION	签名 SIGNATURE	日期 DATE
AO		NEW RELEASE	WANG	2013-05-07

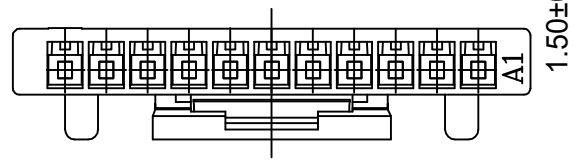
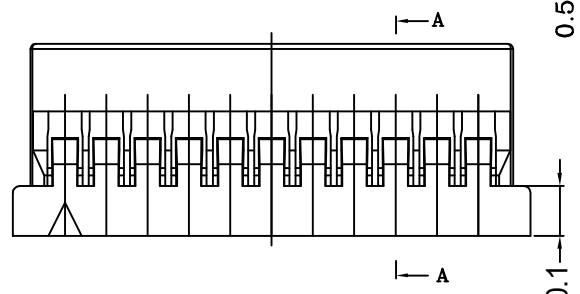
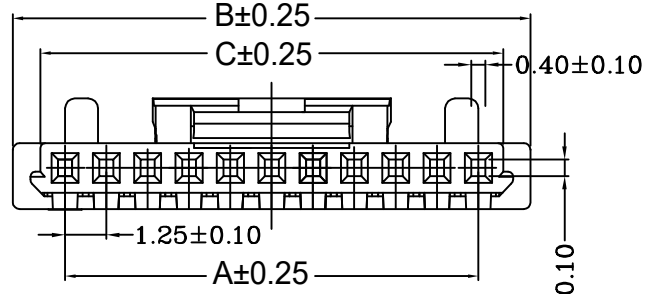
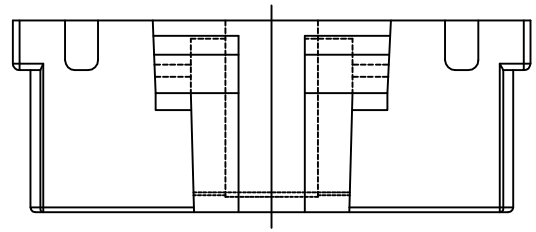

11P~30P

NOTE:
 1. MATERIAL :PA66 UL 94V-0
 2. 0.08mm BURR ALLOWABLE.

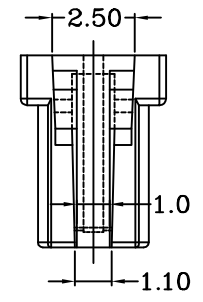

2P

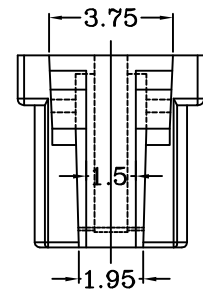

3P

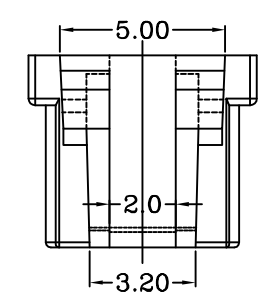

4P

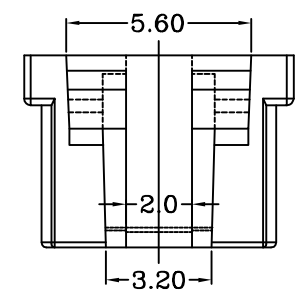

5P

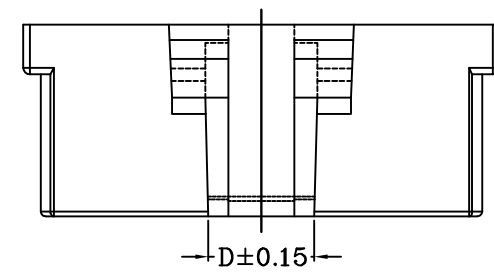
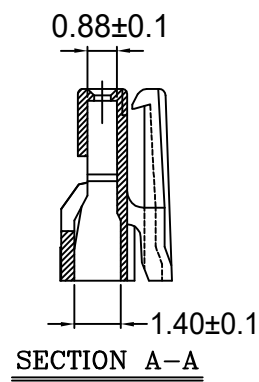
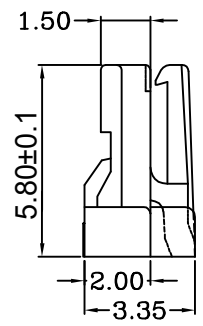

6P~10P

PIN	DIM. (mm)			
	A	B	C	D
02	1.25	4.40	2.75	1.10
03	2.50	5.65	4.00	1.95
04	3.75	6.90	5.25	3.20
05	5.00	8.15	6.50	3.20
06	6.25	9.40	7.75	3.20
07	7.50	10.65	9.00	3.20
08	8.75	11.90	10.25	3.20
09	10.00	13.15	11.50	3.20
10	11.25	14.40	12.75	3.20
11	12.50	15.65	14.00	4.70
12	13.75	16.90	15.25	4.70
13	15.00	18.15	16.50	4.70
14	16.25	19.40	17.75	4.70
15	17.50	20.65	19.00	4.70
20	23.75	26.90	25.25	4.70
25	30.00	33.15	31.50	5.70
30	36.25	39.40	37.75	5.70

深圳市华德共创科技有限公司
 Shenzhen Huade co-create Technology Co.,LTD
 TEL : 0755-27129737 FAX : 0755-29940187

-TOLERANCES- UNLESS OTHERWISE SPECIFIED 公差参数表					TITLE: 产品名称 : 1.25mm Pitch Housing			
X.X	±0.30	X.X°	±3°	APPD: 核准 : XIE	PART NO: 产品编号 : HDGC1255HA-XP			
X.XX	±0.30	X.XX°	±2°	CHECK: 校对 : WANG	DATE	SCALE	UNIT	CODE NUMBER
X.XXX	±0.10	X.XXX°	±1°	DRAW: 绘图 : WANG	2013-05-07	1:1	mm	A001

修订 REV	标记 MARK	修改摘要 REVISION DESCRIPTION	签名 SIGNATURE	日期 DATE
AO		NEW RELEASE	WANG	2018-05-10

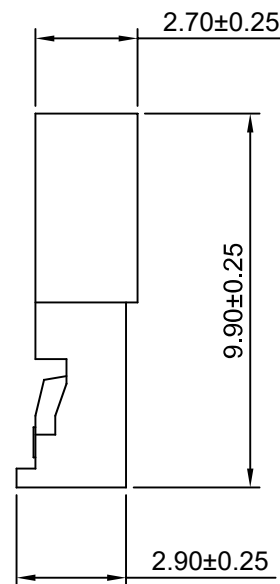
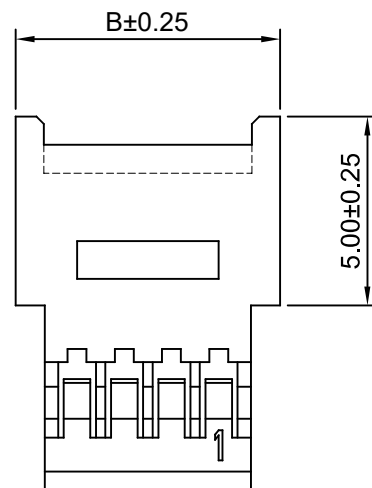
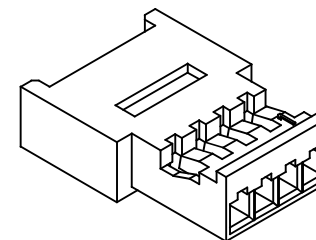
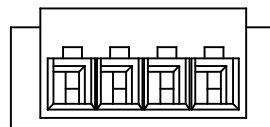
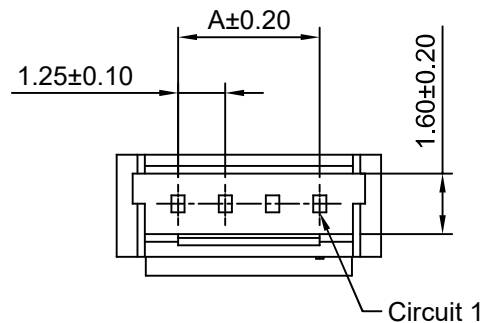

Ordering Information & Dimensions

Circuits	Dimensions(mm)		Circuits	Dimensions(mm)	
	A	B		A	B
2P	1.25	4.50	10P	11.25	14.50
3P	2.50	5.75	11P	12.50	15.75
4P	3.75	7.00	12P	13.75	17.00
5P	5.00	8.25	13P	15.00	18.25
6P	6.25	9.50	14P	16.25	19.50
7P	7.50	10.75	15P	17.50	20.75
8P	8.75	12.00	20P	23.75	27.00
9P	10.00	13.25	25P	30.00	33.25

SPECIFICATIONS:

Current Rating: 1A AC,DC
Voltage Rating: 150V AC,DC
Temperature Range: -25°C ~ +85°C
Contact Resistance: 30mΩ Max.
Insulation Resistance: 500MΩ Min.
Withstanding Voltage: 500V AC/minute
Material: Nylon 66,UL94V-0(White)



深圳市华德共创科技有限公司

Shenzhen Huade co-create Technology Co.,LTD

TEL : 0755-27129737 FAX : 0755-29940187

-TOLERANCES- UNLESS OTHERWISE SPECIFIED 公差参数表						TITLE: 产品名称: 1.25mm Pitch Housing			
X.X	±0.30	X.X°	±3°	APPD: 核准:	XIE	PART NO: 产品编号: HDGC1255HMA-XP			
X.XX	±0.30	X.XX°	±2°	CHECK: 校对:	WANG	DATE	SCALE	UNIT	CODE NUMBER
X.XXX	±0.10	X.XXX°	±1°	DRAW: 绘图:	WANG	2018-05-10	5:1	mm	A008

修订 REV	标记 MARK	修改摘要 REVISION DESCRIPTION	签名 SIGNATURE	日期 DATE
AO		NEW RELEASE	WANG	2017-02-10

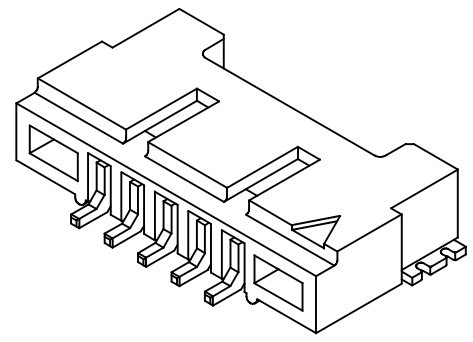
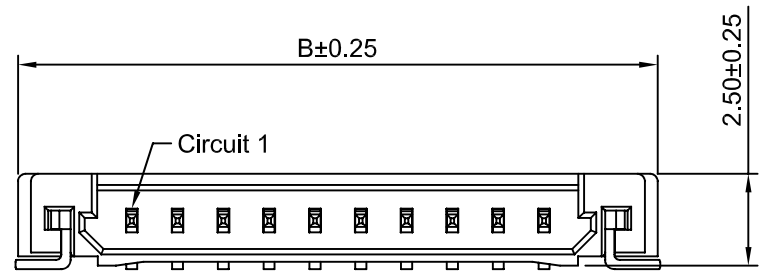
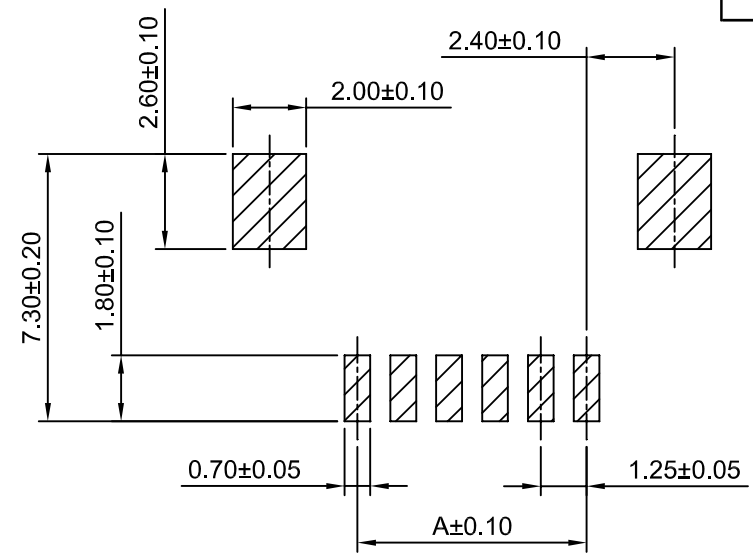
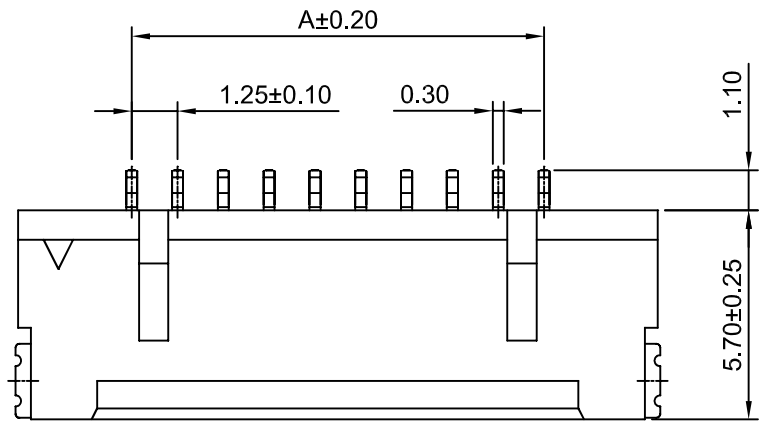

Ordering Information & Dimensions

Circuits	Dimensions(mm)		Circuits	Dimensions(mm)	
	A	B		A	B
2P	1.25	7.45	11P	12.50	18.70
3P	2.50	8.70	12P	13.75	19.95
4P	3.75	9.95	13P	15.00	21.20
5P	5.00	11.20	14P	16.25	22.45
6P	6.25	12.45	15P	17.50	23.70
7P	7.50	13.70	20P	23.75	29.95
8P	8.75	14.95	25P	30.00	36.20
9P	10.00	16.20	30P	36.25	42.45
10P	11.25	17.45			

SPECIFICATIONS:

Current Rating: 1A AC,DC
Voltage Rating: 150V AC,DC
Temperature Range: -25°C ~ +85°C
Contact Resistance: 30mΩ Max.
Insulation Resistance: 500MΩ Min.
Withstanding Voltage: 500V AC/minute
Pin Material: Brass/Tin over Nickel
Solder Tabs: Brass/Tin over Nickel
Material: LCP,UL94V-0(Ivory)

深圳市华德共创科技有限公司
Shenzhen Huade co-create Technology Co.,LTD
TEL : 0755-27129737 FAX : 0755-29940187

-TOLERANCES- UNLESS OTHERWISE SPECIFIED 公差参数表					TITLE: 1.25mm Pitch 产品名称: 90° Wafer				
X.X	±0.30	X.X°	±3°	APPD: 核准:	XIE				
X.XX	±0.30	X.XX°	±2°	CHECK: 校对:	WANG	DATE	SCALE	UNIT	CODE NUMBER
X.XXX	±0.10	X.XXX°	±1°	DRAW: 绘图:	WANG	2017-02-10	5:1	mm	A008

修订 REV	标记 MARK	修改摘要 REVISION DESCRIPTION	签名 SIGNATURE	日期 DATE
AO		NEW RELEASE	WANG	2017-02-10

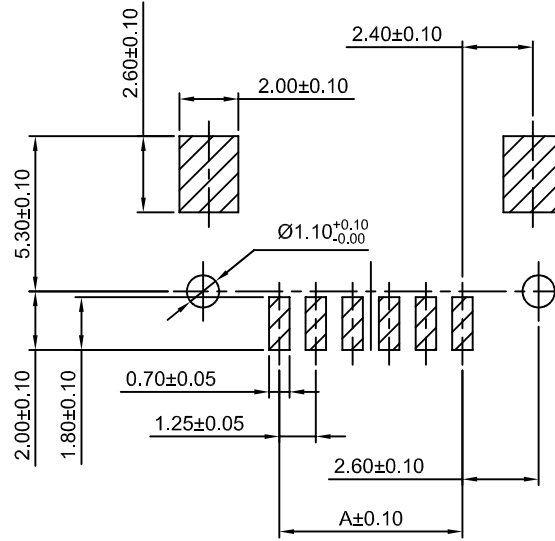
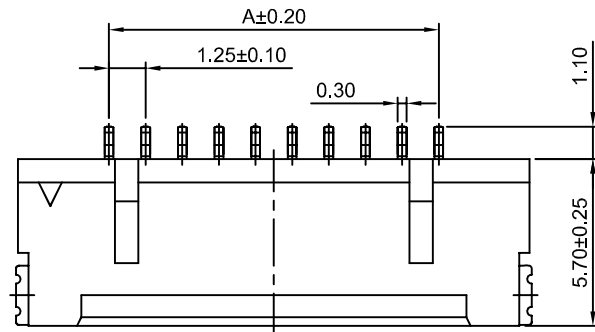

P.C.B. LAYOUT

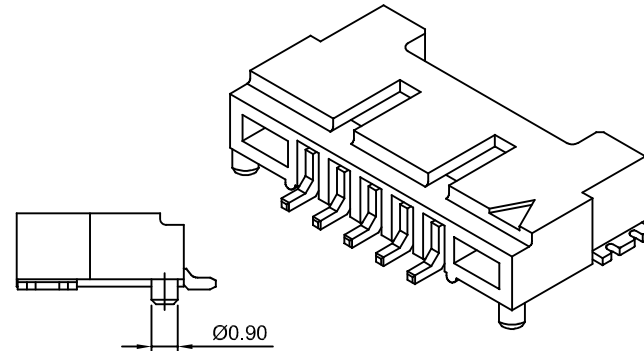
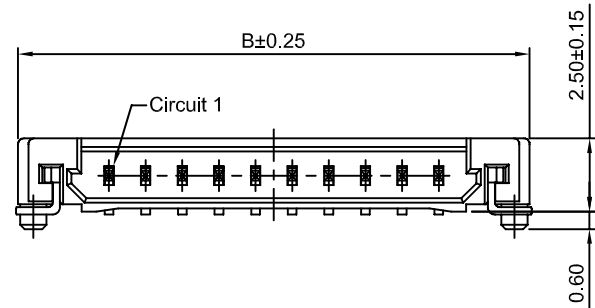

Ordering Information & Dimensions



Circuits	Dimensions	
	A	B
2P	1.25	7.45
3P	2.50	8.70
4P	3.75	9.95
5P	5.00	11.20
6P	6.25	12.45
7P	7.50	13.70
8P	8.75	14.95
9P	10.00	16.20
10P	11.25	17.45
11P	12.50	18.70
12P	13.75	19.95
13P	15.00	21.20
14P	16.25	22.45
15P	17.50	23.70
20P	23.75	29.95
25P	30.00	36.20
30P	36.25	42.45

Unit: mm

SPECIFICATIONS:
 Current Rating: 1A AC,DC
 Voltage Rating: 150V AC,DC
 Temperature Range: -25°C ~ +85°C
 Contact Resistance: 30mΩ Max.
 Insulation Resistance: 500MΩ Min.
 Withstanding Voltage: 500V AC/minute
 Pin Material: Brass/Tin over Nickel
 Solder Tabs: Brass/Tin over Nickel
 Material: Nylon 9T,UL94V-0(Ivory)



深圳市华德共创科技有限公司
 Shenzhen Huade co-create Technology Co.,LTD
 TEL : 0755-27129737 FAX : 0755-29940187

-TOLERANCES- UNLESS OTHERWISE SPECIFIED 公差参数表				 		TITLE: 1.25mm Pitch 产品名称: 90° Wafer			
X.X	±0.30	X.X°	±3°	APPD: 核准:	XIE	PART NO: 产品编号: HDGC1255WR-S-F-XP			
X.XX	±0.30	X.XX°	±2°	CHECK: 校对:	WANG	DATE	SCALE	UNIT	CODE NUMBER
X.XXX	±0.10	X.XXX°	±1°	DRAW: 绘图:	WANG	2017-02-10	4:1	mm	A008

修订 REV	标记 MARK	修改摘要 REVISION DESCRIPTION	签名 SIGNATURE	日期 DATE
AO		NEW RELEASE	WANG	2013-11-22

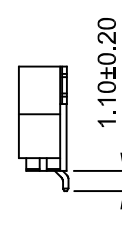
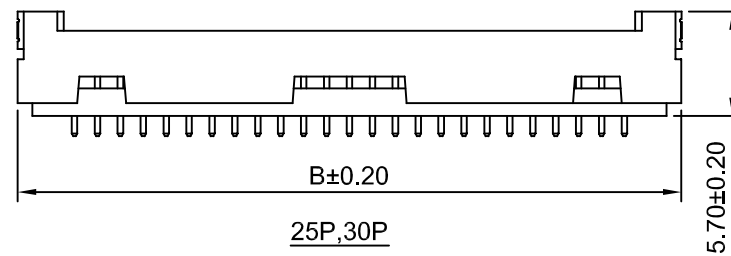
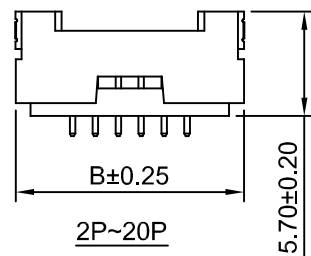
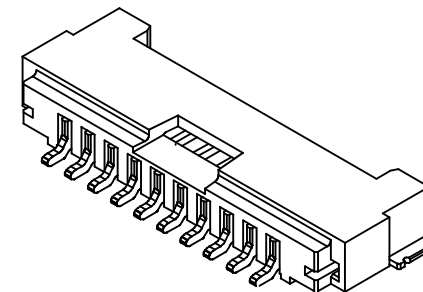
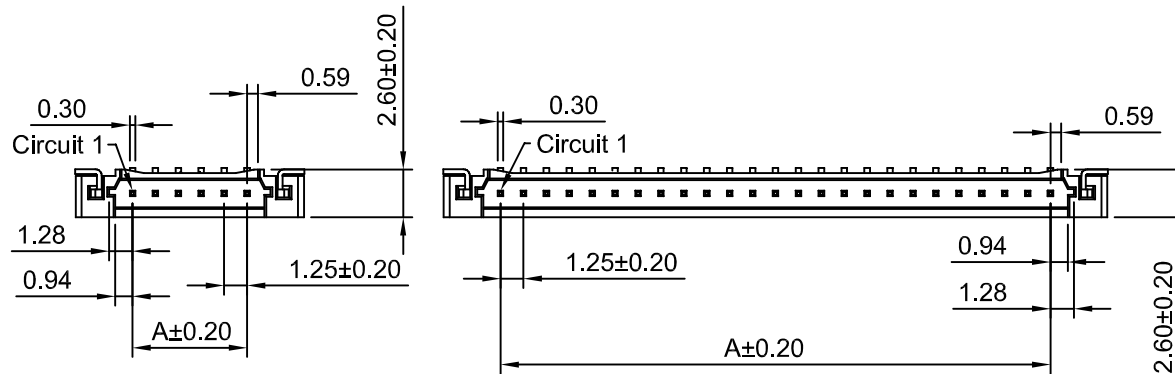

Ordering Information & Dimensions

Circuits	Dimensions(mm)		Circuits	Dimensions(mm)	
	A	B		A	B
2P	1.25	7.45	11P	12.50	18.70
3P	2.50	8.70	12P	13.75	19.95
4P	3.75	9.95	13P	15.00	21.20
5P	5.00	11.20	14P	16.25	22.45
6P	6.25	12.45	15P	17.50	23.70
7P	7.50	13.70	20P	23.75	29.95
8P	8.75	14.95	25P	30.00	36.20
9P	10.00	16.20	30P	36.25	42.45
10P	11.25	17.45			

SPECIFICATIONS:

Current Rating: 1A AC,DC
Voltage Rating: 150V AC,DC
Temperature Range: -25°C ~ +85°C
Contact Resistance: 30mΩ Max.
Insulation Resistance: 500MΩ Min.
Withstanding Voltage: 500V AC/minute
Pin Material: Brass/Tin over Nickel
Material: Nylon 9T, UL94V-0(Beige)

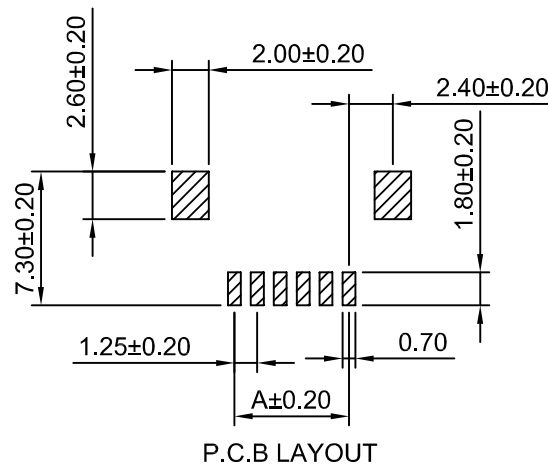

深圳市华德共创科技有限公司
Shenzhen Huade co-create Technology Co.,LTD
TEL : 0755-27129737 FAX : 0755-29940187

-TOLERANCES- UNLESS OTHERWISE SPECIFIED 公差参数表					TITLE: 1.25mm Pitch 产品名称: 90° Wafer						
X.X	±0.30	X.X°	±3°	APPD: 核准:	XIE				PART NO: 产品编号:	HDGC1255WRA-S-XP	
X.XX	±0.30	X.XX°	±2°	CHECK: 校对:	WANG		DATE	SCALE	UNIT	CODE NUMBER	
X.XXX	±0.10	X.XXX°	±1°	DRAW: 绘图:	WANG		2013-11-22	2.5:1	mm	A008	